

Name: _____ Date: _____ Course number: _____
MAKE SURE YOUR TA OR TI STAMPS EVERY PAGE BEFORE YOU START!

Lab section: _____ Partner's name(s): _____ Grade: _____

EXPERIMENT 11

Velocity of Waves

1. Pre-Laboratory Work [2 pts]

1.) What is the longest wavelength at which a sound wave will be resonant in a pipe of length L which is open at one end and closed at the other? Assume that for resonance there will be an anti-node in the displacement of the air at the open end and a node at the closed end. Drawing a picture may be useful. (1 pt)

2.) Give a detailed explanation of how you are going to measure the frequency in the second part of the lab using the sonometer apparatus and an oscilloscope. (1 pt)

Last Revised on December 15, 2014

EXPERIMENT 11

Velocity of Waves

2. Purpose

To determine the speed of sound in air, and to find the relationship between the velocity of a wave in a string, the linear density, and the tension. You will do this by performing two different experiments:

- I. Speed of Sound in Air
- II. Sonometer: Waves in a Stretched String

For the second experiment, the measurements from the oscilloscope is required. Please go to the following video link to get familiar with the oscilloscope before :
<http://www.youtube.com/watch?v=0FFmGOFqInQ>
(or just type “Scope Primer” on the youtube.)

3. Introduction

Recall our knowledge of standing waves established in a stretched string that is fixed at both ends. A wave traveling down the length of the string is reflected at the end and returns in the opposite direction (with the same wavelength). If the length of the string is chosen such that the superposition of these two waves establishes a pattern of standing waves, we call this condition *resonance*. Furthermore, the distance between adjacent nodes in the pattern of standing waves will be half the wavelength of the wave itself.

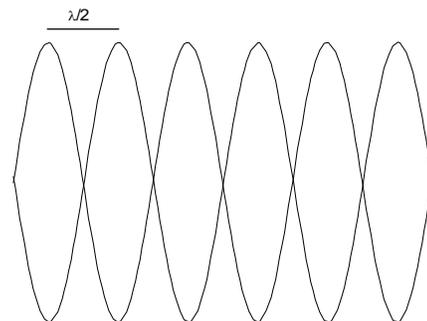

Likewise, standing *sound* waves can be achieved in a tube with either one or both ends open. As with the stretched string, resonance is established if the length of the tube is chosen appropriately according to the wavelength (or frequency) of the sound waves. The open end of the tube corresponds to the location of a displacement anti-node, i.e., where the amplitude of the

oscillation is at its maximum value. The closed end of the tube corresponds to a displacement node, i.e., where the amplitude of the oscillation is zero.

The *fundamental harmonic*, f_0 , corresponds to the lowest frequency at which standing waves are established. The *second harmonic*, f_1 , is the 2^d lowest frequency resulting in standing waves. The same applies for higher order harmonics. Note that the second harmonic has a subscript of '1', this is the standard notation and will be used in this lab.

As we know, the speed (v), the frequency (f), and the wavelength (λ) are related by

$$v = \lambda f \quad \text{Equation 11.1}$$

Thus, if we can determine the wavelength (λ) of sound within a tube and its frequency (f), then we can easily determine the speed of sound (v).

4. Laboratory Work

4.1 Speed of Sound in Air

Introduction

Longitudinal vibrations produced by a tuning fork are transmitted through the air into a plastic tube with an adjustable piston at one end (see Figure 11.1). By suitably adjusting the length of the air column using the piston, standing waves are produced in it. The locations of the nodes of the standing waves are determined by the length of the air column required to produce resonance. By knowing the distance between the nodes, the wavelength of the vibration can be found. Since the frequency of the tuning fork is given, it is stamped on the side of the fork, the speed of sound in the air can be calculated.

Let f , be the frequency of vibration of the tuning fork. This will also be the frequency of the tone in the air column. If λ is the wavelength of the sound in air, then the speed of sound in air is just,

$$v = \lambda f \quad \text{Equation 11.2}$$

Procedure

- 1.) Set up the apparatus as shown in the diagram below. Position the tuning fork at the end of the plastic tube with its edge about 1 cm from the open end of the tube.

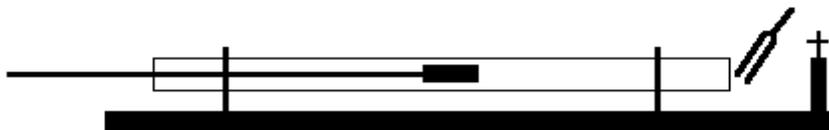

Figure 11.1

- 2.) Firmly strike the tuning fork with the rubber mallet. Be careful that the tuning fork does not strike the tube. Do not strike the fork with or against any hard object as damage may result.
- 3.) Vary the effective length of the tube by moving the piston through its complete range and determine the positions of each of the nodes by listening for resonance. Loud resonance corresponds to an anti-node (also found at the open end of the tube).
- 4.) Record the distance of each node from the open end of the tube in Table 11.1, and make an estimate of the uncertainty in the measurements.
- 5.) Record the frequency of the tuning fork in Table 11.1.
- 6.) Repeat 2)-5) with at least two other tuning forks of different frequencies.

4.2 Sonometer: Waves in a Stretched String

Introduction

The Somometer is shown in the diagram below. This apparatus allows us to vary the tension (T), length (L) and linear density (μ) of the string and to observe the changes in the frequencies of the vibrated string.

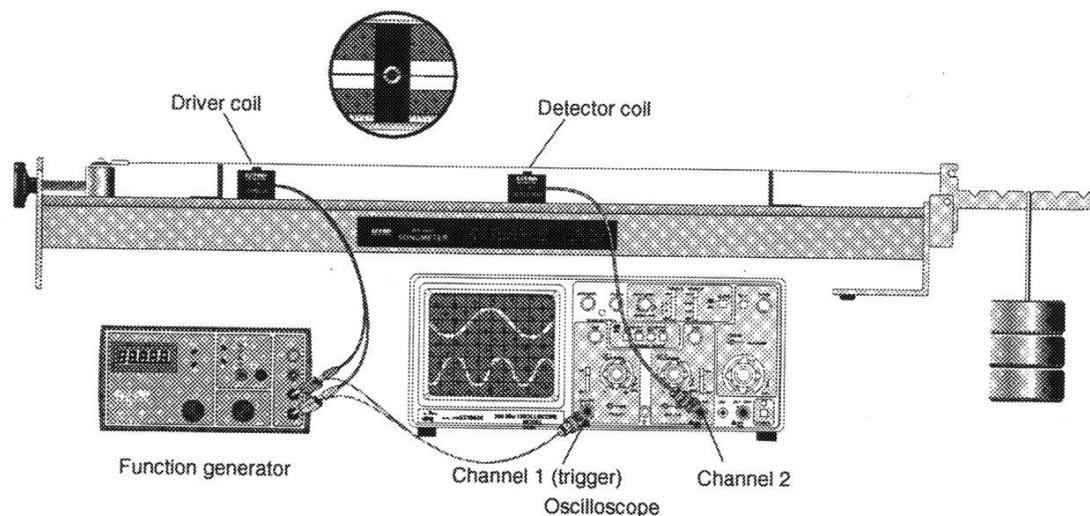

Figure 11.2

The driver and the detector coil can be placed anywhere along the string. The driver coil drives the string vibrations at any frequency your function generator will produce. The frequency observed on the wire is usually **twice** the driver frequency because the driver electromagnet exerts a force on the wire twice during each cycle. The detector coil allows you to view the vibration of the string on your oscilloscope. Set the amplitude of the function generator to its maximum value in order to see the largest string vibrations.

4.2.1 Standing Waves in a Known Wire

In this section of the lab we will be using the Sonometer to look for and identify the standing wave modes in a stretched string.

Procedure

- 1.) Start with the bridges 60 cm apart. Use any of the included strings and hang a mass of approximately 1 kg (being sure to include the mass of the hanger itself) from the first slot of the tensioning lever (see Figure 11.3). Adjust the string adjustment knob so that the tensioning lever is horizontal. Position the driver coil 5 cm from one of the bridges and position the detector coil near the center of the wire. Record the length, tension (N) and linear density of the string in Table 11.2.

Color Code	Diameter (inches)	Linear Density, μ (g/m)
White	0.010	0.39
Blue	0.014	Unknown
Red	0.017	1.12
Yellow	0.020	Unknown
Black	0.022	1.84

- 2.) Calculate the resonant frequency of the *fundamental harmonic*, f_0 , using,

$$v = \lambda_0 f_0 \quad \text{Equation 11.3}$$

where $\lambda_0 = 2L$ and the velocity of the wave is related to the tension and the linear density in the following way,

$$v = \sqrt{\frac{T}{\mu}} \quad \text{Equation 11.4}$$

- 3.) Slowly increase the frequency of the signal to the driver coil, starting at 25 Hz. Listen for an increase in the volume of the sound from the sonometer and/or an increase in the size of the detector signal on the oscilloscope. Frequencies that result in the maximum string vibration are resonant frequencies. Determine the lowest frequency at which resonance occurs. This resonance is the first, or *fundamental*, harmonic. Measure the frequency of the standing wave using the oscilloscope. You do so, by measuring the period, τ , of the wave in the string using the detector coil. The period is calculated knowing the number of divisions between peaks and the time per division. There will be some uncertainty, $\Delta\tau$, from this measurement based on the precision with which you can read the period from the oscilloscope. The frequency is simply the inverse of the period.
- 4.) Continue increasing the frequency of the driver coil to find successive resonant frequencies (at least 2 or 3). Think about how the frequencies and wavelength for harmonics are related to the fundamental frequency and wavelength.

- 5.) Record the number of anti-nodes, the measured and calculated resonance frequency for each harmonic in Table 11.2. Think about how the number of anti-nodes is related to the order of the harmonic.
- 6.) When done with the wire, put it back in the appropriate location.

4.2.2 Finding the Linear Density of an Unknown Wire

In this section of the lab, you will determine the linear density of an unknown wire using the Sonometer apparatus.

Procedure

- 1.) Replace the wire on the Sonometer with a color coded unknown wire. Then with the set up the same as in the previous section measure the *fundamental harmonic*, f_0 , using 5 different tensions. Vary the tension by keeping the mass the same, but changing the location of the mass on the tensioning lever (see Figure 11.3). Change the string adjustment knob each time you move the mass so that the tensioning lever is always horizontal.

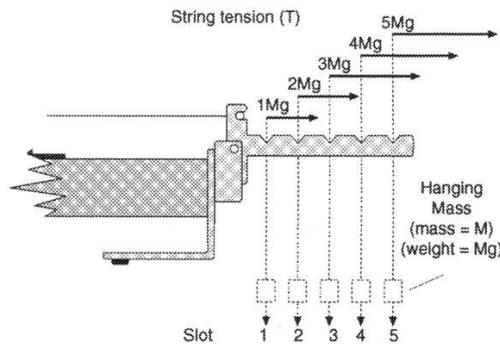

Figure 11.3

- 2.) Record the color code of the unknown wire, as well as, the node spacing, and the period of the wave as picked up by the detector coil using the oscilloscope for each of the five tensions in Table 11.3.
- 3.) When done with the wire, put it back in the appropriate location.

Name: _____ Date: _____ Course number: _____
MAKE SURE YOUR TA OR TI STAMPS EVERY PAGE BEFORE YOU START!

Lab section: _____ Partner's name(s): _____ Grade: _____

Setup Materials Confirmation: TA/TI Signature _____

(Return all lab materials to original state to match image reference before Post-Lab will be accepted)

EXPERIMENT 11

Velocity of Waves

5. Post-Laboratory Work [20 pts]

5.1 Speed of Sound in Air [8 pts]

Measurement Data

- 1.) Record the frequency of the tuning fork, and the distance from each node to the open end of the tube.

Frequency (Hz)	Distance to Node (m)	Distance to Node (m)	Distance to Node (m)

Table 11.1

Calculations

- 2.) Calculate the average distance between consecutive nodes for each frequency. This distance is $\lambda/2$ for the sound wave. Show a sample calculation below. (2 pts)

3.) Calculate the speed of sound in air for each of the tuning forks. Show your work.
(2pts)

4.) Determine the average velocity of sound in air and its uncertainty using the standard deviation of your three velocity values. Show your work. (2pts)

5.) Using your value of the uncertainty from above, compare your results with the value resulting from the following formula for the speed of sound in air as a function of temperature,

$$v = v_0 \sqrt{1 + 0.004T} \quad \text{Equation 11.5}$$

where $v_0 = 332$ m/sec is the speed of sound in air at 0°C and T is the temperature in degrees Celsius. (2pts)

5.2 Sonometer: Waves in a Stretched String

5.2.1 Standing Waves in a Known Wire [12 pts]

6.) Calculate the resonant frequency of the *fundamental harmonic* using Equations 11.3 and 11.4. Show your work. (1 pt)

7.) Record the number of anti-nodes, the calculated and the measured resonant frequencies for a given length of string, tension and linear density. (1 pt)

Length of String =		Tension =		Linear Density =
Number of Anti-Nodes	Calculated Resonant Frequency (Hz)	Measured Period, τ (sec)	Uncertainty in Measured Period, $\Delta\tau$ (sec)	Measured Resonant Frequency (Hz)

Table 11.2

5.2.2 Finding the Linear Density of an Unknown Wire

8.) Record the color code of the unknown wire, the node spacing, and the period of the wave for each of the five tensions.

Color Code of the Unknown Wire: _____

Tension, T (N)	Node Spacing (cm)	Period, τ (sec)

Table 11.3

Calculations

9.) Calculate the velocity and the uncertainty in the velocity of the wave for each of the five tensions using the measured wavelength and the period of the *fundamental harmonic*. Hint, how do you relate the period of the *fundamental harmonic* as measured on the oscilloscope to its frequency. Use propagation of error to find that the uncertainty in the velocity is $\Delta v = \frac{\lambda \Delta \tau}{\tau^2}$, assuming the measured wavelength has

no error associated with it. Put your results in Table 11.4. Show your work for one calculation. (3 pts)

Tension (T)	λ (m)	f (Hz)	v (m/s)	Δv (m/s)	Δv^2 (m/s)

Table 11.4

10.) Plot v^2 versus T on the axis provided. Include labels, units, and the uncertainty in v^2 . The uncertainty in the square of the velocity is just $\Delta v^2 = 2(\Delta v) * v$. Is the relationship linear? Find the slope of the line. This slope is $1/\mu$, where μ is the linear density of the unknown wire. Show your work. (3 pts)

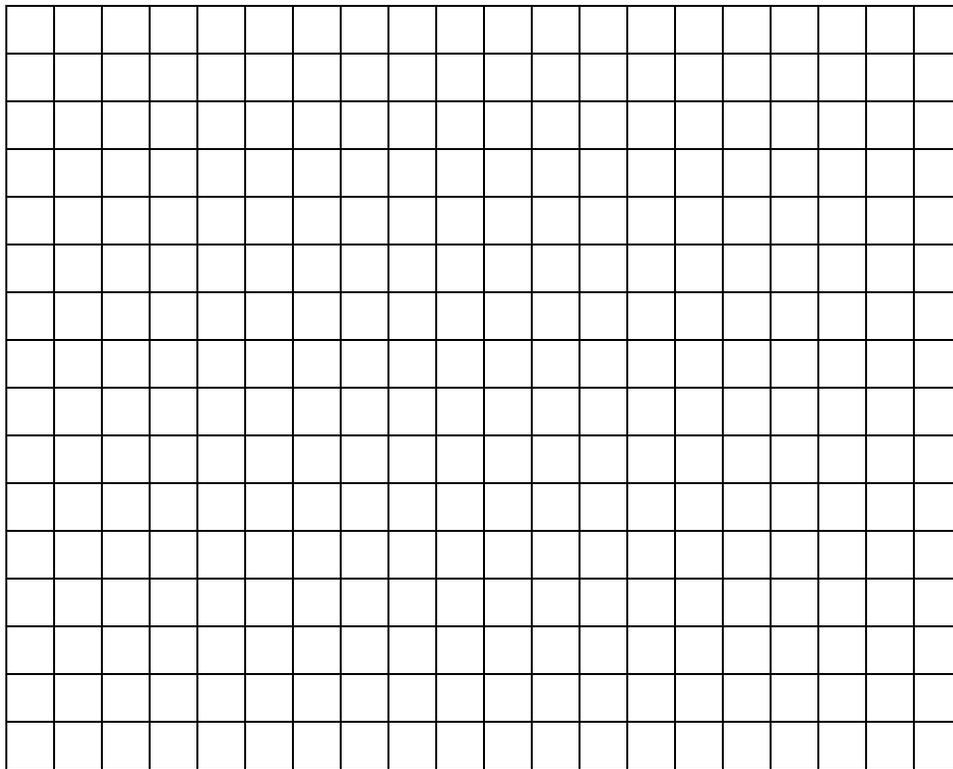

- 11.) Calculate the error in $1/\mu$ from the max./min. slopes as found in the graph above. This means that you calculate a maximum and a minimum slope through the high and the low error bars, and then use these slopes to calculate an average slope and the error or uncertainty in the average slope. Consider the following example: (3 pts)

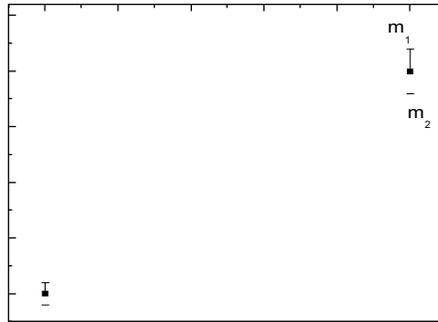

where m_1 is the maximum slope and m_2 is the minimum slope. Then the average slope is just the following:

$$\bar{m} = \frac{|m_1 + m_2|}{2} \quad \text{Equation 11.6}$$

In addition, the error or uncertainty in this average slope is just:

$$\Delta m = \frac{|m_1 - m_2|}{2} \quad \text{Equation 11.7}$$

- 12.) How does the value of μ from the slope compare to the accepted value of your color coded wire? Is it within error of the accepted value? (Ask your TA for the accepted value of μ for your unknown wire.) (1 pt)