

Name: _____ Date: _____ Course number: _____
MAKE SURE YOUR TA OR TI STAMPS EVERY PAGE BEFORE YOU START!

Lab section: _____ Partner's name(s): _____ Grade: _____

EXPERIMENT 8

Electron Beams

0. Pre-Laboratory Work [2 pts]

1. Name the 2 forces that are equated in order to derive the charge to mass ratio relationship. (1pt)

2. Describe or make a rough sketch of the path of an electron traveling into a region with a constant B-field. (Assume the B-field is out of the page and the initial velocity of the electron is perpendicular to the B-field.) In this experiment, what provides the B-field? (1pt)

Last Revised on December 15, 2014

EXPERIMENT 8

Electron Beams

1. Purpose

The purpose is to derive an expression for e/m and to develop a working knowledge of magnetic field effects on charged particle beams.

2. Introduction

This self-contained apparatus is designed for the measurement of the charge e to mass m ratio, $|e/m|$, of the electron by observing their circular paths under the influence of a uniform magnetic field B .

A particle with charge q , traveling with velocity \mathbf{v} through a region with a uniform electric \mathbf{E} and magnetic \mathbf{B} field, will experience a force called the Lorentz force, \mathbf{F}_L , where

$$\vec{F}_L = q(\vec{E} + \vec{v} \times \vec{B}).$$

For this experiment, our charged particle is an electron ($q = e$) and is steadily supplied by an electron beam. A pair of Helmholtz coils provides the uniform magnetic field oriented perpendicular to the velocity (or path) of the electron. There is no electric field present. For this case, the Lorentz force reduces to

$$F_L = evB.$$

A description of the apparatus follows: The magnetic field is along the axis of the Helmholtz coils. The vacuum tube has a downward pointing electron gun in an evacuated tube that has a little helium added so that the path of the electrons in the tube is visible. The overall appearance of the apparatus is shown in Figure 8.1.

Three internal power supplies provide the filament power, the coil current and the accelerating potential for the electron beam. The filament supply is fixed while the accelerating voltage and the coil current are set by front panel controls. Two digital meters on the front panel read out the accelerating potential and the coil current. The meters make it simple to accurately determine the forces affecting the motion of the electrons within the tube. The diameter of the electron path in the magnetic field can be measured using the etched glass internal scale in the tube. The

graduations and numerals of the scale are illuminated by the collision of the electrons, making observation and reading easier.



Figure 8. 1

The helium gas added to the tube fluoresces when struck by the moving electrons and produces a bright, clear view of the electron beam. An electrode is provided for absorbing electrons after they have traced their circular path. Thus, the circular tracing of the electron path is undisturbed by previously emitted electrons, contributing to more accurate measurement.

The general configuration of the electron gun is shown in Figure 8.2. A heated cathode at the top of the figure emits electrons. The cathode is connected to the negative of the high voltage supply. It is partially shielded by a surrounding grid that has a small aperture to let some electrons pass through. The anode is mounted below the grid and is connected to the high voltage positive. Electrons escaping through the grid hole are rapidly accelerated toward the anode by the potential difference between them. Most of the electrons hit the anode, but some of them pass through the hole in the anode and form the electron beam in the tube.

The energy given to an electron falling through the potential, V , is eV , where V is the anode potential and e is the charge on the electron. All of this energy is converted into kinetic energy of the moving electron (where v is the electron's velocity and m is its mass),

$$\frac{1}{2}mv^2 = eV \quad \text{Equation 8.1}$$

so

$$v = \left(2eV/m\right)^{1/2} \quad \text{Equation 8.2}$$

The electron beam is deflected into a circular path by the Lorentz force, evB . This force provides the centripetal force, mv^2/r required to maintain the circular motion. Equating these forces, you get,

$$evB = mv^2/r \quad \text{Equation 8.3}$$

and therefore,

$$eB = mv/r \quad \text{Equation 8.4}$$

From these two equations (Equations 8.2 and 8.4), an expression for e/m can be derived,

$$e/m = 2V/(r^2 B^2) \quad \text{Equation 8.5}$$

Helmholtz coils surrounding the vacuum tube provide the magnetic field. They are mounted so that their field is transverse to the tube axis and the electron's motion. These coils produce a nearly uniform magnetic field everywhere inside of the volume they enclose. This is a very useful property, since it guarantees that there is a constant force on the moving electrons. In addition to field uniformity, the magnitude of the magnetic field can be calculated from,

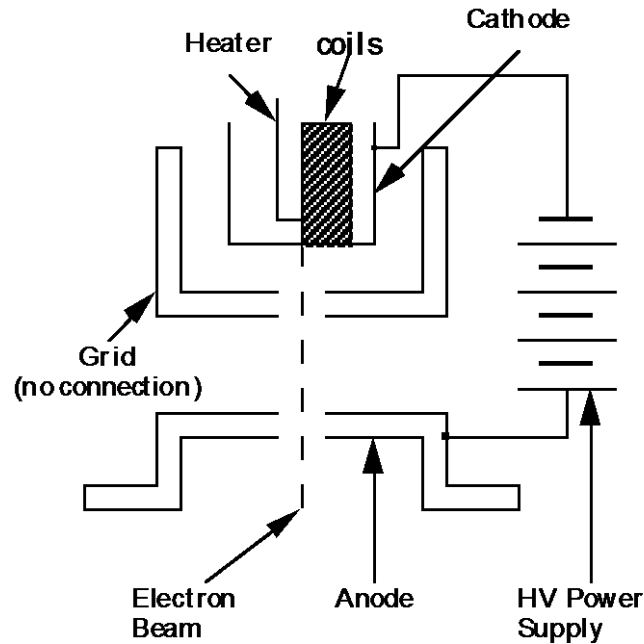

Figure 8. 2

MAKE SURE TA & TI STAMPS EVERY PAGE BEFORE YOU START

$$|B| = \left(\frac{4}{5}\right)^{3/2} \frac{\mu_o NI}{a} \quad \text{Equation 8.6}$$

where $\mu_o [=1.26 \times 10^{-6} \text{ H/m}]$ is the permeability of free space, N is the number of turns in each of the pair of coils (130 per coil), I is the coil current and a is the coil radius ($\sim 0.15\text{m}$),

$$\frac{|B|}{I} = 0.77 \text{ mT/A} \quad \text{Equation 8.7}$$

Your coil radius will be a little different from this value, so measure the dimensions carefully. Also, the coils may not be completely circular, so multiple measurements of their diameter will ensure a good average coil diameter value. As an exercise compute the coefficient in Equation 8.6 and compare to Equation 8.7.

3. Laboratory Work

Introduction

In this laboratory experiment you will use this self-contained apparatus to obtain an experimental value for the charge to mass ratio of the electron. Record all your data in the Tables provided in *Section 4*, the *Post-Laboratory Report*.

Procedure

1. Set the apparatus on a level table. The room light should not be too bright, because the electron beam will be hard to see. You may want to use the "box" with the window.
2. In order to minimize the influence of geomagnetism, use a compass to locate magnetic North and align the Helmholtz coils axis so they are perpendicular to the needle. **Note:** If this is not convenient, it can be disregarded with little effect on the results (certainly less than other errors in the measurement). This will have the effect of reducing the influence of geomagnetism on the magnetic field parallel to the coil axis. The influence of geomagnetism or other sources of magnetic fields can be observed by the deflection of the circular motion of the electron beam while the apparatus is rotated. The magnitude of this deflection is greater when a small current is flowing through the coils.
3. With the power switch *off*, make sure the apparatus is plugged in.
4. Turn *on* the power switch. The unit will perform a 30-second self-test, indicated by the digital display changing values rapidly. During the self-test, the controls are locked out, allowing the cathode to heat to the proper operating temperature. When the self-test is complete, the display will stabilize and show "000." Although the unit is now ready for operation, a 5-10 minute warm-up time is recommended before taking measurements.

MAKE SURE TA & TI STAMPS EVERY PAGE BEFORE YOU START

5. Turn the *Voltage Adjust* control up to 200V and observe the bottom of the electron gun. The bluish beam will be traveling straight down to the envelope of the tube. **Note:** Both the Voltage and Current outputs are controlled by an on-board microprocessor. Because the microprocessor automatically locks out the controls at both the minimum and maximum settings, there is no need to provide a manual "stop" on the knobs. When the knob reaches the maximum setting, it will still turn, although the value shown on the appropriate display will not change. This feature prevents excessive loads from being placed on the tube and provides a smooth, jitter-free display.
6. Turn the *Current Adjust* control up and observe the circular deflection of the beam. When the current is high enough, the beam will form a complete circle within the envelope. The diameter of the beam can be measured using the internal centimeter scale inside of the tube. The scale numbers fluoresce when struck by the electron beam.
7. For an accelerating voltage of 200V, measure the beam diameter for nine coil current settings.
8. Set the accelerating voltage to 300V, repeat the procedure in Steps 5 and 6, and measure the beam diameter for nine coil current settings.
9. Repeat for one additional accelerating voltage.
10. If a small ceramic magnet is available, move it close to the tube and observe the deflection of the beam. It is easy to see how properly designed magnets can be used to focus and steer an electron beam.
11. Reset both controls to zero and switch *off* the apparatus.
12. Measure the internal and external diameter of the Helmholtz coils across several diameters. They may not be quite round and the two coils may not be quite the same. Use Equation 8.6 (with proper units!) with your measured radius to recalculate Equation 8.7's coefficient for use in your statistical analysis.
13. Average your measurements and determine the standard error, so that you will be able to decide whether it has a significant effect on the accuracy of your results.

Note to TAs: If the electron gun is not pointed downward, the electron beam will travel on a spiral path. To correct this, loosen the mounting screws of the vacuum tube and rotate the tube a little until the electron gun is in the proper orientation and the beam is circular. This adjustment should be done by a laboratory technician before the laboratory session and not left to the student.

Last Revised on December 15, 2014

Name: _____ Date: _____ Course number: _____
MAKE SURE YOUR TA OR TI STAMPS EVERY PAGE BEFORE YOU START!

Lab section: _____ Partner's name(s): _____ Grade: _____
Setup Materials Confirmation: TA/TI Signature _____

(Return all lab materials to original state to match image reference before Post-Lab will be accepted)

EXPERIMENT 8

Electron Beams

4. Post-Laboratory Work [20 pts]

4.1 Data Records: Coil Radius (1pt)

Record the coil current and beam diameter for the nine (9) trials, for each of the three (3) accelerating voltages in the 3 data tables that follow.

You will be using Equation 8.5 to calculate the charge/mass ratio of the electron. That equation uses the quantity $(rB)^2$ and the voltage, V , to yield e/m . The data you recorded is the coil current, I (Amps), and the diameter of the electron beam's path, d (meters). To convert these values directly to rB (in units of meter-Tesla), and fill out the data tables, use this relationship: $rB = (\text{coefficient on the order of magnitude } 10^{-4}) d \cdot I$ **Equation 8.8**

Note: make sure your coefficient contains 2 decimal places.

Record your average value of the Helmholtz coil radius here: $a =$ _____

1. Please calculate the coefficient using the following formulas. Show your calculations and record your calculated value below. Use your calculated value for the remainder of the lab. (1pt)

$$r = \frac{1}{2}d, \quad B = \left[\frac{\mu_0 NI}{a} \right] \left[\frac{4}{5} \right]^{\frac{3}{2}}$$

$$rB = \text{_____} d \cdot I$$

MAKE SURE TA & TI STAMPS EVERY PAGE BEFORE YOU START

For each set of 9 trials, you are asked to calculate the *mean*, *true standard deviation*, and the *standard error of the mean*. These three quantities are defined below:

$$\text{Mean: } \bar{rB} = \frac{\sum_{k=1}^9 (rB)_k}{9}$$

$$\text{True Standard Deviation: } \sigma_{true} = \sqrt{\frac{\sum_{k=1}^9 [(rB)_k - (\bar{rB})]^2}{9-1}}$$

$$\text{Standard Error of the Mean: } \sigma_{mean} = \frac{\sigma_{true}}{\sqrt{9}}$$

When you have completed the statistical analysis for the 3 data sets, calculate e/m from Equation 8.5 for each of the three accelerating voltages. You will calculate an error bar for e/m using the ideas of Propagation of Error where the *standard error of the mean* will be used as the uncertainty in the value of rB

$$\text{Random Error in } e/m: \quad \Delta(e/m) = 2 \left[\frac{(e/m)\sigma_{mean}}{rB} \right]$$

At the end of the data analysis, you will have found 3 different values for e/m and its random error, one for each of the three accelerating voltages. The proper way to quote your results will be, for instance:

$$e/m = 1.91 \times 10^{11} \pm 0.02 \times 10^{11} \text{ C/kg}$$

The following are incorrect ways to quote your result. Make sure you see why each one is incorrect. If you are not sure, ask a TA or TI. In this lab report, it is especially important that you think carefully about significant figures in your results. In general, you should never report more than 3 significant figures for this lab, and in some cases, fewer are justifiable.

$$e/m = 1.91 \times 10^{11} \pm 0.0205 \times 10^{11} \text{ C/kg}$$

$$e/m = 1.9 \times 10^{11} \pm 0.0005 \times 10^{11} \text{ C/kg}$$

$$e/m = 1.9 \times 10^{11} \pm 2.05 \times 10^9 \text{ C/kg}$$

MAKE SURE TA & TI STAMPS EVERY PAGE BEFORE YOU START

4.2 Data Records: First Voltage (3pts)

Voltage: _____

N	Coil Current (A)	Diameter (m)	$r \cdot B (m \cdot T)$
1.			
2.			
3.			
4.			
5.			
6.			
7.			
8.			
9.			

Mean:

True Standard Deviation:

Standard Error:

e/m:

Random Error in *e/m*:

Final Result (*e/m* +/- error with units):

MAKE SURE TA & TI STAMPS EVERY PAGE BEFORE YOU START

4.3 Data Records: Second Voltage (3pts)

Voltage: _____

N	Coil Current (A)	Diameter (m)	$r \cdot B (m \cdot T)$
1.			
2.			
3.			
4.			
5.			
6.			
7.			
8.			
9.			

Mean:

True Standard Deviation:

Standard Error:

e/m:

Random Error in *e/m*:

Final Result:

MAKE SURE TA & TI STAMPS EVERY PAGE BEFORE YOU START

4.4 Data Records: Third Voltage (3pts)

Voltage: _____

N	Coil Current (A)	Diameter (m)	$r \cdot B (m \cdot T)$
1.			
2.			
3.			
4.			
5.			
6.			
7.			
8.			
9.			

Mean:

True Standard Deviation:

Standard Error:

e/m:

Random Error in *e/m*:

Final Result:

MAKE SURE TA & TI STAMPS EVERY PAGE BEFORE YOU START

4.5 Questions (10pts)

2. Make a plot on the grid below of e/m vs. accelerating voltage(y vs. x!!) and include error bars determined from your calculation of the random error in e/m . Include axes labels with units. Use scientific notation in your y-axis label by stating it in terms of 10^{11} C/kg. Draw a line at a y-axis value of 1.759×10^{11} C/kg as this is the accepted value of e/m . (4pts)

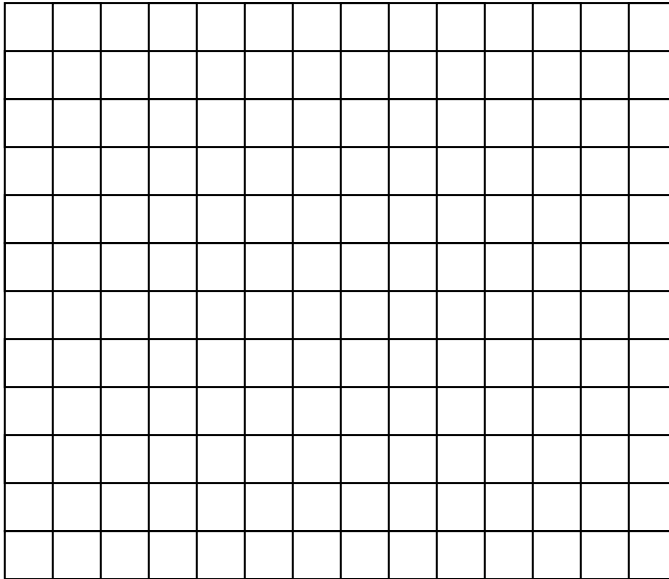

3. Taking into account each measured value with its associated error, are your results consistent with each other? With the true value? Explain your answer and discuss why or why not. (4pts)

4. Name at least 2 of the major sources of error in the measurement of e/m for this lab. Be specific, i.e. “human error” as a reason is insufficient as it is imprecise. (2pts)