

9. Lecture, 30 September 1999

9.1 Telescopes in general

Astronomers always want their telescopes to have large light-collecting areas, because they observe very faint objects, and large, flat, unblurred fields of view, because the sky tends to have interesting structure on all observed angular scales. Mirrors, rather than lenses, meet the former requirement best. It is hard to make large enough pieces of glass free enough of bubbles, color and cloudiness to be of much use in telescopes. It is hard to support them mechanically, since they must be held by their edges, which is the weakest part of a converging lens. The variation of the refractive index of glass with wavelength, or *dispersion*, limits the range of wavelength over which aberrations can be corrected. The largest telescope objective lenses ever made are the Yerkes Observatory 40 inch (1 m) and the Lick Observatory 36 inch (0.91 m), both built by the Alvan Clarks (a famous father-and-son team of opticians) in the 1890s. These telescopes still see regular use, but because astronomers have other telescopes a factor of ten larger in diameter these days, the refractors no longer contribute to the solution of problems at the frontiers of astrophysics.

Mirrors, on the other hand, need not be made of transparent materials, and can be supported solidly from their back sides. Their use in telescopes is therefore universal, at all wavelengths from X rays to radio. At ultraviolet, visible and infrared wavelengths, the mirrors are commonly made of polished low-expansion glass or glassy ceramics, coated with thin metallic and dielectric films to make them reflective.

The supporting structure and mechanisms required for a modern telescope are complex, and we will therefore not attempt to describe them completely here. Mirrors in ground-based telescopes are usually held up by open space-frame structures that in most cases are designed to flex under their weight in such a way that the mirrors remain nearly coaxial; then the only correction that needs to be made when the telescope orientation is changed is a motion of the secondary mirror along its axis. That this is a relatively difficult and costly task is indicated by the resemblance of large numbers of big telescopes to each other. For example, the apparent similarities among many telescopes in the 2-5 meter diameter class are due to the common use of an arrangement of beams called the Serrurier truss. Another example is provided by the Keck and Hobby-Eberly 10-m telescopes; the space frame structures for these three telescopes not only look the same, but were designed by the same engineer.

For the telescope to point at objects in arbitrary places in the sky, the telescope has to be provided with mechanisms to rotate it around two perpendicular axes. Two such schemes are in use: *equatorial* (or *polar*) and *altitude-azimuth* mounts. The latter mount, usually called "alt-az," is superficially the simplest. It involves rotations about a horizontal axis -- measured by the altitude or elevation, the angle between the telescope axis and horizontal -- and a vertical axis, through the local zenith, measured counterclockwise from north to the projection of the telescope axis on the ground. Figure 9.1 is an illustration of this scheme. The principal advantage of the alt-az mount is that it can bear more weight with less flexure than the equatorial mount, because the weight of the telescope from its center of mass can be designed to lie along the axis of the support structure. It is also the more compact of the two, usually fitting underneath the telescope, and therefore results in a system that can be enclosed by a smaller, less-expensive dome. There are two principal disadvantages, however. First is the necessity of mechanisms and control systems to drive the telescope in both altitude and azimuth, at variable speeds, to follow a celestial object across the sky, because the angular coordinates of altitude and azimuth are quite different from celestial latitude and longitude except if the telescope is built at the north or south pole. With the advent of inexpensive microcomputers this is no longer much of a difficulty, but early radio telescopes were sometimes built with complex mechanical or analog computers to translate between the two coordinate systems. Second is a more fundamental difficulty: the rotation of the field of view about the optical axis, from the point of

view of a detector fixed in position with respect to the telescope. Removal of this image rotation involves an additional mechanism and control system to rotate either the instrument or the image in synch with the rotation of the sky.

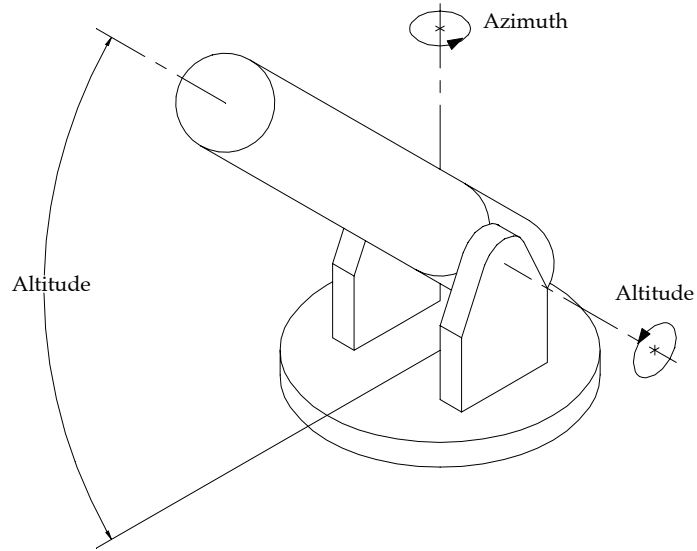

Figure 9.1: altitude-azimuth telescope mount.

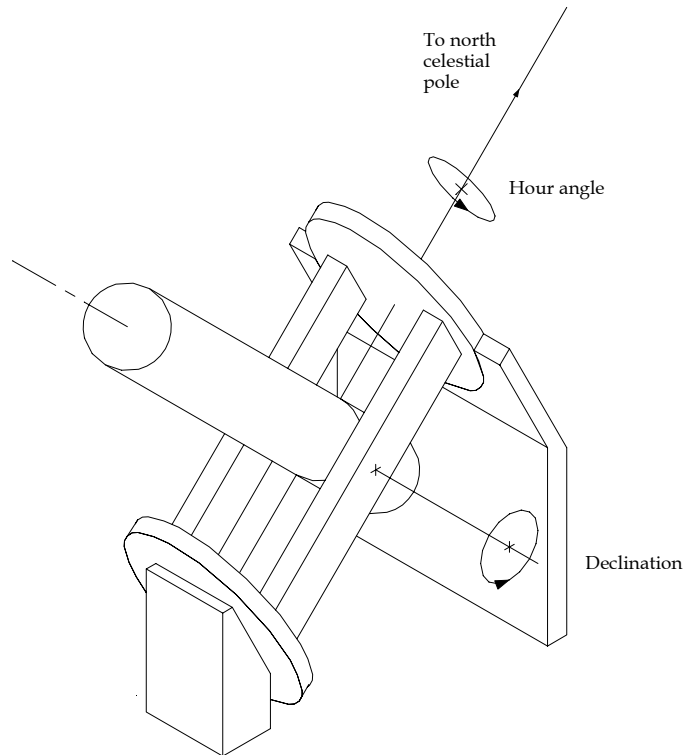

Figure 9.2: equatorial, or polar, telescope mount.

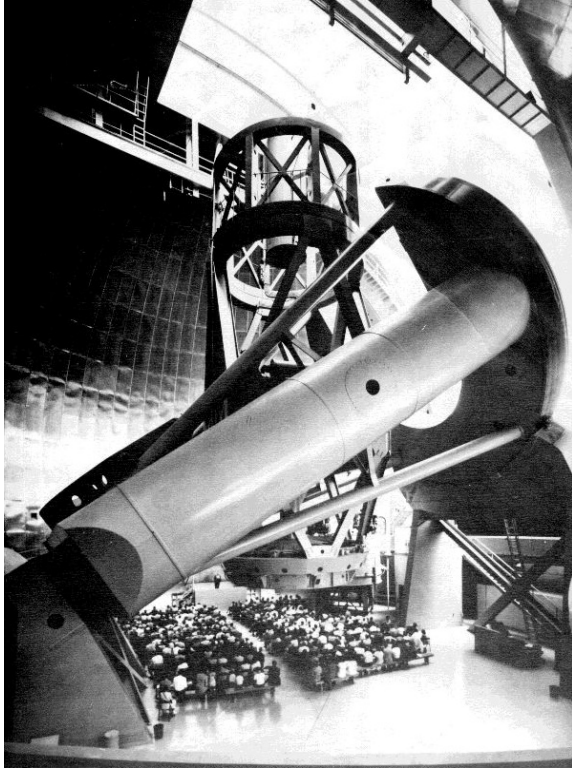

Figure 9.3: The 200-inch Hale telescope at its dedication in 1948. The telescope pivots in declination about an axis through the dark spot on the face of the large strut in the foreground. It is steered in right ascension about an axis through the large bearing at left and the center of the “horseshoe” at right. (Caltech Archives)

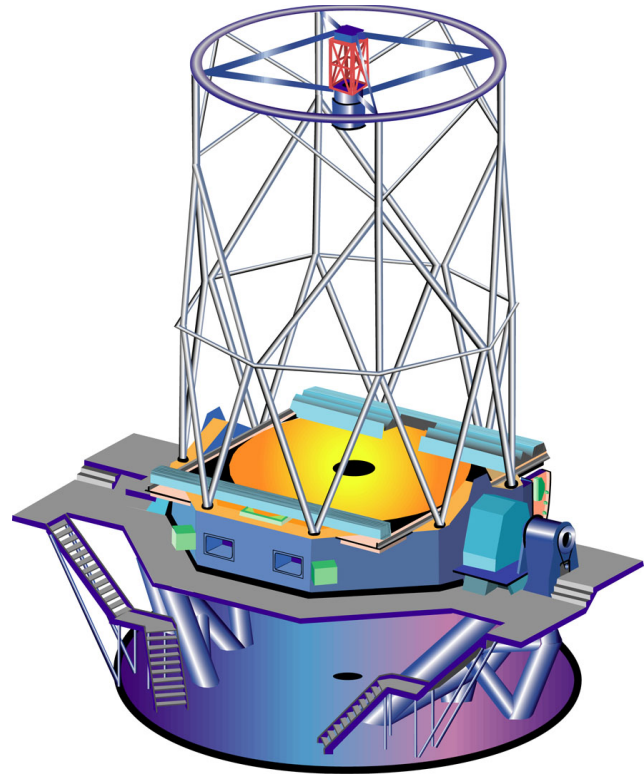

Figure 9.4: drawing of one of the Gemini telescopes, with its alt-az mount and partially-covered 8.1 m primary mirror. The entire structure as pictured rotates about a vertical axis to point the telescope in azimuth, and the telescope pivots in elevation about an axis through the trusses shown just above the upper platform. (Gemini Observatory)

Both of these difficulties are avoided in the equatorial-polar mount, shown in Figure 9.2. In this system one of the telescope axes is aligned parallel with the Earth's rotation axis, pointing at the north celestial pole. Swiveling the telescope about this *polar* axis, with the other dimension fixed, moves the field of view of the telescope's field of view in the same direction that non-solar-system objects appear to move due to Earth's rotation. Thus only one, constant-speed, motor drive is necessary to track the stars. The angular coordinate corresponding to rotation about the polar axis is called the *hour angle* (*HA*). It is measured in hours, minutes and seconds of time from the direction of a north-south meridian through the local zenith, and is directly related to the celestial longitude coordinate, *right ascension* (*RA*), and the *local sidereal time* (*LST*):

$$HA = RA - LST \quad . \quad (9.1)$$

The orthogonal *equatorial* axis gives rise to an angle, measured from the polar axis in degrees, minutes and seconds of arc, that is identical to the celestial latitude coordinate, *declination*. If the polar axis is well-aligned with Earth's rotation, no object-tracking controller is needed for the equatorial axis unless solar system objects are to be observed, and the field of view of the focal plane detectors does not rotate on the sky. The largest and best-known visible-infrared telescope with a equatorial mount is the 200-inch (5 m) Hale telescope at Palomar Observatory, shown in Figure 9.3

Table 9.1: the new generation of large visible and infrared telescopes

Name	Organizations	Location	Diameter (number of telescopes)
W.M. Keck Observatory	Caltech, U. California, NASA	Mauna Kea, Hawaii	11×10 m hexagon (2)
MMT (formerly the Multiple- Mirror Telescope)	Smithsonian Astrophysical Observatory, U. Arizona	Mt. Hopkins, Arizona	6.5 m
Subaru	National Astronomical Observatory of Japan	Mauna Kea, Hawaii	8.3 m
Gemini	United States, United Kingdom, Canada, Chile, Australia, Argentina, Brazil	Mauna Kea, Hawaii and Cerro Pachón, Chile	8.1 m (2)
Hobby-Eberly Telescope	University of Texas, Pennsylvania State U., Stanford U., Ludwigs-Maxmilians U., Georg- August U.	Mt. Fowlkes, Texas	11×10 m hexagon
Very Large Telescope	European Southern Observatory	Cerro Paranal, Chile	8.2 m (4)
Large Binocular Telescope	Osservatorio Astrofisico di Arcetri (Italy), U. Arizona, Arizona State U., Northern Arizona U., LBT Beteiligungsgesellschaft (Germany), Ohio State U., Research Corporation	Mt. Graham, Arizona	8.4 m (2)

Until relatively recently only radio telescopes used alt-az mounts. The new generation of very large visible and infrared telescopes, begun by the 6-m Large Altazimuth Telescope (LAT) in southern Russia in the late 1970s, involves such massive and bulky structures that only the alt-az mount is considered. Table 9.1 is a list of the telescopes presently operating or under construction that are larger than the LAT and the Palomar 200-inch; all have alt-az mounts. An example, one of the Gemini 8.1 m telescopes, is shown in Figure 9.4.

For satellite observatories the mechanical considerations are somewhat different, since the structure must be as light as possible and must survive the 10-20g accelerations of launch, but once deployed suffers no gravitational sag. Telescope pointing is usually accomplished by motion of the entire spacecraft, through the use of small compressed-gas thrusters and *reaction wheels*, as illustrated in Figure 9.5. After deployment, the spin of the satellite is brought to a halt with respect to the fixed stars by use of the compressed-gas thrusters and the combination of star-tracker cameras. At this point the satellite has zero angular momentum, and can be pointed precisely to a reference position, and subsequently to celestial objects of interest, by turning the two orthogonal-axis reaction wheels with respect to the rest of the satellite: from the point of view of the celestial sphere the reaction wheel and the rest of the spacecraft move in opposite angular increments in the ratio of the moments of inertia of wheel and spacecraft. The thrusters can also be used to “unload” the reaction wheels should it be desired to place a reference position in a certain spot in the angular range of a reaction wheel.

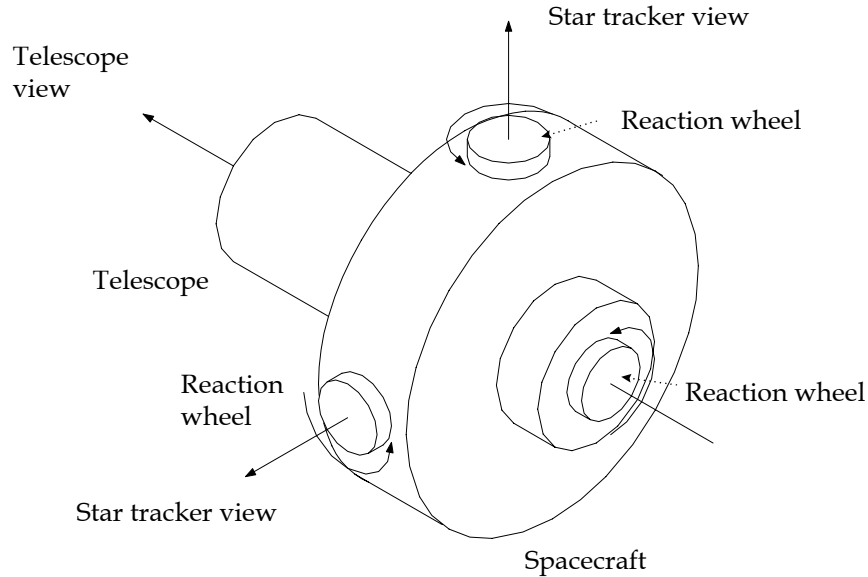

Figure 9.5: functional schematic of a satellite observatory, showing three reaction wheels and two star-tracking cameras for orientation of the telescope and focal plane. The axes of the reaction wheels pass through the center of mass of the system. Not shown are the nozzles of compressed-gas thrusters that can exert torque on the spacecraft along the reaction-wheel axes.

9.2 Aberration compensation in two-mirror telescopes

For several decades following the construction of the first truly large telescopes, the 100-inch (2.5 m) Hooker reflector at Mt. Wilson Observatory (1917) and the 200-inch (5 m) Hale reflector at Palomar Observatory (1948), other large telescopes were almost exclusively built in their image: with paraboloidal primary mirrors and optionally with a selection of convex hyperboloidal secondary mirrors. A single paraboloid is of course the simplest telescope that lacks spherical aberration. Most of the important results obtained with the 100-inch, and many of those with the 200-inch, employed the telescope in this fashion, with photographic plates placed at the (prime) focus of the primary mirror. The paraboloid-hyperboloid combination is called the *classical Cassegrain* telescope; it shares with the paraboloid-concave ellipsoid *Gregorian* telescope the lack of spherical aberration (see §3.2), and is generally preferred over the latter because its smaller primary-secondary distance leads to a substantially shorter, and therefore stiffer, telescope structure.

Classical Cassegrains also have the useful property that a given primary mirror can be used with an arbitrary number of secondary mirrors without changing the aberrations; all that is required is for the secondary to be adjusted into alignment with its near focus coincident with the primary's focus. It is customary for two-mirror telescopes to have at least two secondaries, for the standard setups illustrated in Figure 9.6. One of them relays the final focus behind the primary in the usual Cassegrain configuration. The other has a much longer second focal length and is used with a flat tertiary mirror that directs the beam down the elevation or declination axis of the telescope. This latter configuration is called the *coudé* (equatorial mount) or *Nasmyth* (alt-az mount) focus. The virtue of the *coudé*/*Nasmyth* focus is that it enables the use of instruments too heavy or bulky to be fastened directly to the telescope.

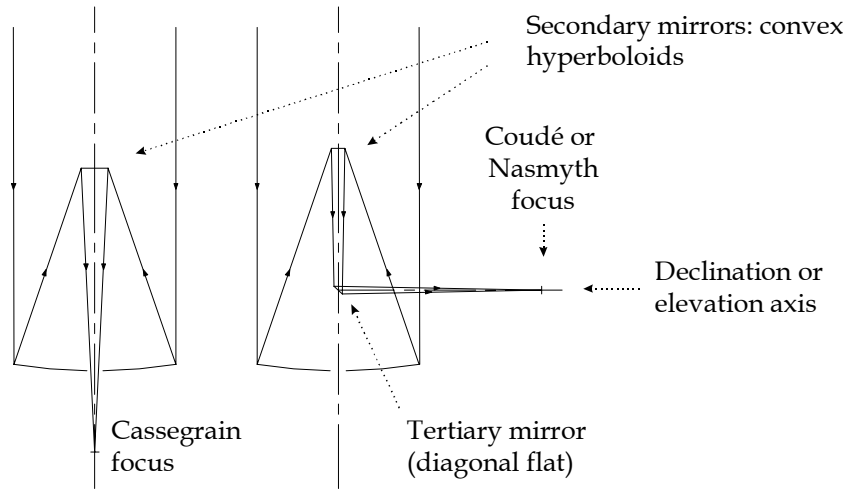

Figure 9.6: The classical Cassegrain (left) and coudé (right) configurations of a paraboloid-primary telescope with two interchangeable hyperboloid secondary mirrors and a flat diagonal tertiary mirror.

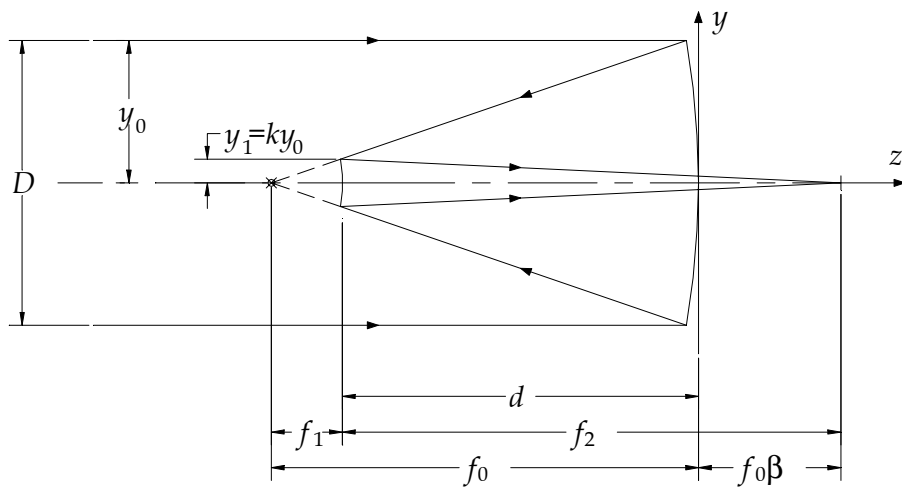

Figure 9.7: classical Cassegrain telescope, with focal lengths, diameters and other parameters defined.

The classical Cassegrain telescope is shown in Figure 9.7. It is often convenient to define the following dimensionless parameters associated with the geometry of the telescope. We label the primary and secondary with the subscripts 0 and 1, in which case the ratios of apex curvatures and diameters are

$$\rho = \kappa_0 / \kappa_1 \quad , \quad k = y_1 / y_0 \quad . \quad (9.2)$$

The secondary focal lengths f_1 and f_2 are $1 / \kappa_1 (\epsilon_1 \pm 1)$. The image at the Cassegrain focus is therefore magnified laterally with respect to prime focus by the factor

$$m = \frac{f_2}{f_1} = \frac{\epsilon_1 + 1}{\epsilon_1 - 1} = \frac{\rho}{\rho - k} \quad , \quad (9.3)$$

and thus the plate scale is smaller than that at prime focus by the factor $1/m$. From Equation 9.3 we also get a handy expression for the secondary eccentricity:

$$\epsilon_1 = \frac{m + 1}{m - 1} \quad . \quad (9.4)$$

The distance from the primary apex to the Cassegrain focal plane is $f_0\beta$, for which it turns out that

$$1 + \beta = k(m + 1) \quad . \quad (9.5)$$

For example, let the magnification and diameter ratio be $m = 5$ and $k = 1/5$; then Equations 9.3-9.5 give $\rho = 0.25$, $\epsilon = 1.5$ and $\beta = 0.2$.

One can analyze the performance of a Gregorian telescope in a manner different only in sign convention from that of the Cassegrain telescope. Because rays reflected by the primary cross the optical axis (and change sign in y) on their way to the secondary, and form a real image at the prime focus, the dimensionless constants k and m have signs opposite those of the corresponding Cassegrain with the same mirror diameters and focal lengths. By the same token, the radii of curvature of primary and secondary have opposite signs in Gregorian telescopes. Otherwise the Cassegrain and Gregorian telescopes are basically the same, optically, so we shall discuss only one of them - the Cassegrain - in the following.

The classical Cassegrain has no spherical aberration, and its unblurred field of view is limited by coma, as we found in Homework Problem Set #2. It is not the only two-mirror configuration that is free of SA, however; we can generate the properties of a whole family of third-order SA-free "Cassegrain" telescopes as follows. Consider a Cassegrain system and another two mirror system with the same apex curvatures and apex distances made by bending the Cassegrain mirrors in the same direction, as shown in Figure 9.8. The paraxial foci of the two telescopes, their secondary magnifications, and final plate scales are all the same; only the aberrations due to the different paths of the marginal rays are different. We can work out

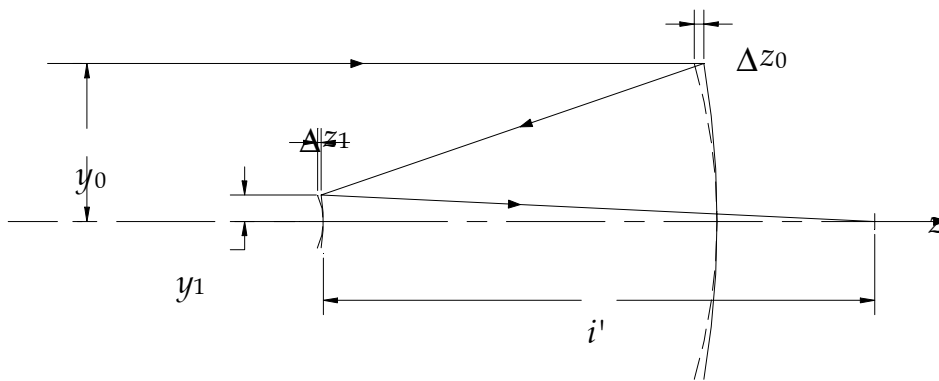

Figure 9.8: modified Cassegrain telescope surfaces (broken lines) and classical Cassegrain reference surfaces (solid lines), with surface displacements Δz_0 and Δz_1 for marginal rays shown highly exaggerated for clarity.

the conditions under which the third-order spherical aberration of the modified telescope is zero by using the classical Cassegrain as a reference surface and calculating the angular aberrations.

The angular aberration suffered by a marginal ray is simply $AA = d(2\Delta z_0) / dy$, as usual. With the mirror surface bent toward negative z , as shown in Figure 9.8, this ray would intersect the axis closer to the primary apex than in the classical Cassegrain; bent in the other direction, the intersection would be further away. The angular aberration for a marginal ray on the secondary is given by $AA = -d(2\Delta z_1) / dy$, because with the modified mirror surface bent toward negative z , a given ray would intersect the axis *further* toward positive z than it would in the case of the reference secondary – the opposite direction of the primary's aberration. The same is true if the secondary is bent, with the primary, toward positive z . Evidently if the mirrors of a Cassegrain are bent in the same direction the aberrations they introduce thereby tend to cancel. They cancel precisely if

$$AA = \frac{d}{dy}(2\Delta z_0 - 2\Delta z_1) = 0 \quad , \quad (9.6)$$

or
$$2\Delta z_0 - 2\Delta z_1 = \text{constant} = 0 \quad (9.7)$$

for this to be true for arbitrary y .^{*} From Equation 7.10 we have third-order expressions for the reference surfaces:

$$z_0(\text{reference}) = \frac{\kappa_0 y_0^2}{2} \quad , \quad (9.8)$$

and
$$z_1(\text{reference}) = \frac{\kappa_1 y_1^2}{2} + \left(1 - \left(\frac{m+1}{m-1}\right)^2\right) \frac{\kappa_1^3 y_1^4}{8} \quad . \quad (9.9)$$

Only the eccentricities of the mirrors have changed, so to third order the modified surfaces are given by

$$z_0(\text{modified}) = \frac{\kappa_0 y_0^2}{2} + \frac{(1 - \varepsilon_0^2) \kappa_0^3 y_0^4}{8} \quad , \quad (9.10)$$

$$z_1(\text{modified}) = \frac{\kappa_1 y_1^2}{2} + \frac{(1 - \varepsilon_1^2) \kappa_1^3 y_1^4}{8} \quad . \quad (9.11)$$

Substituting Equations 9.8-9.11 into Equation 9.7, we get

^{*} If the constant in Equation 9.6 is zero, then not only do the angular aberrations cancel but the rays travel paths that are the same length in the modified system as in the reference system. The path length can be shown to be a minimum in the case of the SA3-free reference system, in harmony with the elegant rephrasing of geometrical optics known as *Fermat's principle*, so one might naturally expect that a modified system with the same path lengths would also lack SA3. This is why one often sees the present aberration analysis cast in the form of Fermat's principle, as by Schroeder in our AST 403 textbook *Astronomical Optics*. I prefer to note that if the path lengths are the same ($\Delta z_0 - \Delta z_1 = 0$) then the angular aberrations cancel, as they must if the telescope is to remain SA3-free after modification.

$$1 - \varepsilon_0^2 = \frac{\kappa_1^3 y_1^4}{\kappa_0^3 y_0^4} \left(\left(\frac{m+1}{m-1} \right)^2 - \varepsilon_1^2 \right) = \frac{k^4}{\rho^3} \left(\left(\frac{m+1}{m-1} \right)^2 - \varepsilon_1^2 \right) , \quad (9.12)$$

an expression that generates what we may call the *family* of Cassegrain telescopes. Given a magnification and ratio of diameters (which as before determines the ratio of apex curvatures and back-focal distance), and a value for the secondary eccentricity, the primary eccentricity that gives zero third-order spherical aberration may be derived. This expression applies to Gregorian telescopes as well, subject to the sign conventions discussed above.

Two special results of Equation 9.12 deserve our attention. First, consider the case of a convex *spherical* secondary, $\varepsilon_1 = 0$. This involves mirror bending, relative to a reference Cassegrain, in the direction drawn in Figure 9.8. If we take $m = 5$ and $k = 1/5$ as before (implying $\rho = 0.25$, $\beta = 0.2$), then the primary eccentricity comes out to $\varepsilon_0 = 0.877$. This combination of a convex spherical secondary and a concave *ellipsoidal* primary is called a *Dall-Kirkham* telescope. Its attractions include cost: the two mirrors are more easily ground and tested than most telescope mirrors. UR astronomers sometimes use a 60-inch (1.5 m) Dall-Kirkham at the Mt. Lemmon Observatory, in the Catalina Mountains near Tucson, AZ.

Also of worthy of note is a particular arrangement of mirror surfaces bent in the direction opposite that shown in Figure 9.8, for which both mirrors turn out to be hyperboloids. It can be shown that if

$$\begin{aligned} \varepsilon_0^2 &= 1 + \frac{2(1+\beta)}{m^2(m-\beta)} \\ \varepsilon_1^2 &= \left(\frac{m+1}{m-1} \right)^2 + \frac{2m(m+1)}{(m-\beta)(m-1)^3} \end{aligned} \quad (9.13)$$

then *coma* as well as spherical aberration is absent from the system *, leaving astigmatism as the only blurring aberration and significantly increasing the size of the unblurred field of view. This of course is the *Ritchey-Chrétien* telescope; we saw in Homework Problem Set #2 how one compares to a classical Cassegrain with the same paraxial parameters. If once again we take $m = 5$ and $k = 1/5$ (so that $\rho = 0.25$ and $\beta = 0.2$), then the eccentricities for the primary and secondary become 1.0200 and 1.5637. It is left to the interested reader to verify by ray tracing that of the three two-mirror telescopes just mentioned, the one with the widest (best) unblurred field of view is the Ritchey-Chrétien, and the one with the smallest (worst) is the Dall-Kirkham, with the increasing prominence of coma providing most of the degradation as one moves from R-C to classical Cassegrain to Dall-Kirkham.

* Optical systems free of coma and spherical aberrations are called *aplanats*.