

Physics 142 – Fall 2010 – Workshop module 6

1. In which 120-V light bulb does the filament have the greater resistance ... a 60-Watt bulb or a 120-Watt bulb? If the two bulbs are connected to a 120-V line in series, across which bulb will there be the greater voltage drop? What if they are connected in parallel?
2. When the switch in the diagram below is open, the voltmeter V reads 1.56 V. When the switch is closed, the voltmeter reading drops to 1.45 V, and the ammeter A reads 1.3 A. Find the emf and internal resistance of the battery. Assume that the two meters are ideal, so they don't affect the circuit.

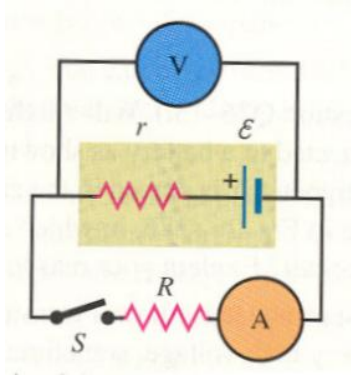

3. When a capacitor, battery and resistor are connected in series, does the resistor affect the maximum charge stored on the capacitor? Why or why not? What purpose does the resistor serve?
4. A resistor with $R=86.0 \text{ k}\Omega$ is connected to the plates of a charged capacitor with capacitance $C=4.5 \mu\text{ F}$. Just before the connection is made, the charge on the capacitor is 0.0636 C . What is the energy initially stored in the capacitor? What is the electrical power dissipated in the resistor just after the connection is made? What is the electrical power dissipated in the resistor at the instant when the energy stored in the capacitor has decreased to half the initial value?
5. Spaceman Spiff takes off from Earth in his trusty spacecraft and moves at a speed $0.99c$ toward the planet Zorgon which is 26 light years distant. How much time will have elapsed by Earth clocks when Spiff arrives at Zorgon? According to Spiff, how much older is he when he arrives at Zorgon than he was when he left Earth. (*Ignore any non-inertial effects in the problem*).
6. As Spiff zips through the Gorgon atmosphere at $0.5c$ in the x -direction, he spots a Zorogonese sailing ship also moving in the x -direction. The Zorogonoids manufacture sailing ships with masts of length 10m that lean away from the direction of movement with an angle that makes 60 degrees with the horizontal. What does Spiff measure for the angle which the Zorogon mast makes with the horizontal?

7. Find the value of the current through each of the three resistances in the circuit below.

