

Name:

Partners' Names:

Laboratory Section:

Laboratory Section Date:

Grade:

Last Revised on August 31, 2005

# EXPERIMENT 12

## Geometrical Optics

### 0. Pre-Laboratory Work [2 pts]

1. Determine the locations of the images for the objects shown below. Label the image as real or virtual; magnified or reduced; erect or inverted. (1pt)

Convex lens

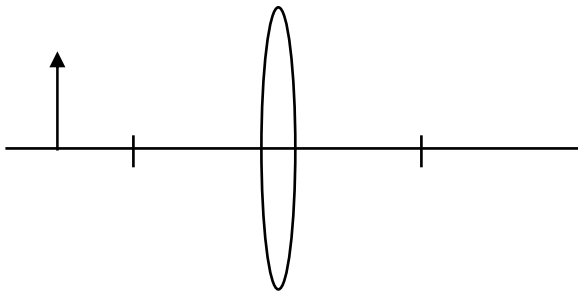

Concave lens

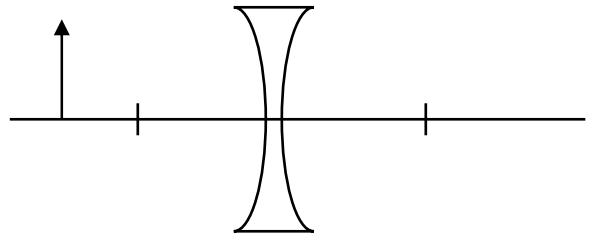

2. You will be making many measurements of “apparent magnification” in this laboratory. Explain how you will make this measurement to come up with a value for magnification. (1pt)

Name:  
Laboratory Section:  
Laboratory Section Date:

Partners' Names:  
Grade:

Last Revised on August 31, 2005

# EXPERIMENT 12

## Geometrical Optics

### 1. Purpose

The purpose of this experiment is to verify the thin lens equation and to construct simple optical systems using various combinations of lenses.

### 2. Introduction

Lenses produce different types of images, depending on the position of the object relative to the lens and its focal point. In the following discussion, we use the descriptions of real or virtual, erect or inverted, and reduced or magnified to describe these images. The fundamental distinction between real and virtual images is that light rays converge to form a real image, while light rays diverge from a virtual image; real images may be projected onto a screen while virtual images must be viewed through a lens system such as the eye.

In this experiment, we use a simple “optical bench,” a magnetized track upon which various combinations of objects and lenses can be mounted. The distance between a lens and object,  $o$ , is called the object distance. The distance between a lens and image,  $i$ , is called the image distance. Denoting the focal length of a lens by,  $f$ , we may use the optical bench to verify the thin-lens equation for a given lens, image distance, and object distance,

$$\frac{1}{i} + \frac{1}{o} = \frac{1}{f}$$

**Equation 12.1**

The optical bench will be used to construct a Projector, a Compound Microscope and two types of long-range magnifiers: the Astronomical and Terrestrial Telescopes.

### 3. Laboratory Work

#### 3.1 The Projector

In the first part of the experiment, you will build a Projector using a single convex lens, an object to project, and a screen on which to view the projected image. A Projector is a simple lens system that focuses an image on a distant screen. By measuring a series of object

distance/image distance pairs, you will be able to experimentally determine the focal length of the convex lens. The thin-lens equation is an approximation, do not be disturbed if your results differ from those predicted by Equation 12.1.

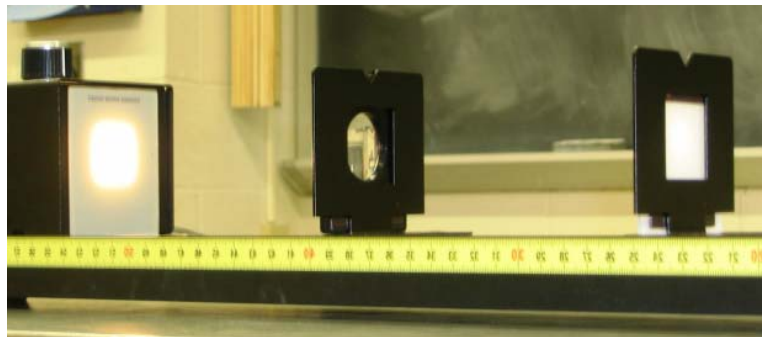
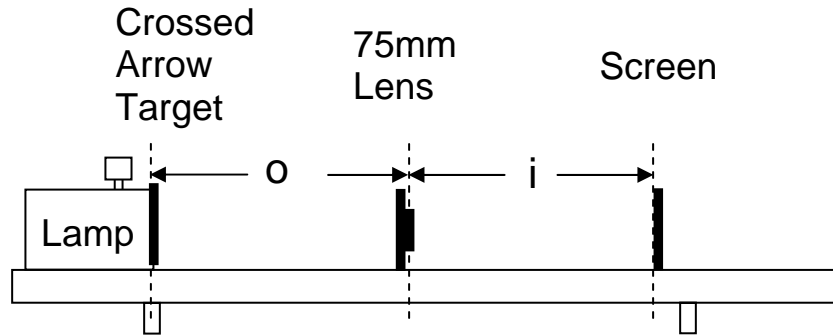

**Figure 12.1**

### Procedure

1. Use the 75mm focal length convex lens (#14), a crossed arrow target as the object (#8), a viewing screen (#11), and 2 element holders (#22) to hold the lens and screen in your design. Set up the optical bench as in *Figure 12.1*. Place the lamp at one end of the bench and direct its illumination parallel to the bench axis using the knob on the top. You may attach the crossed arrow target directly to the lamp housing. Place the lens 10cm away from the crossed arrow target (object). Place the screen on the opposite side of the lens as from the target. Adjust the screen so the projected image is as sharply focused as possible.

**Figure 12. 1**

2. Measure the distance from the center of the lens to the plane of the screen,  $i$ , and the distance from the center of the lens to the object,  $o$ , and record these values in *Table 12.1*. The image may seem to be in sharp focus over some measurable distance. This is called the 'depth of focus'. Estimate this 'depth of focus' in the image distance,  $\Delta i$ , and record it in *Table 12.1*.

3. For each pair of object/image distances, describe the image using the terms real or virtual, erect or inverted, magnified or reduced. It may be difficult to identify each pair definitively, but you should see a trend emerge.
4. Repeat *Step 2-3* for many different object distances, exploring the range from 10 – 20cm in increments of 2cm.
5. In *Section 4.1* you will be asked to predict what value the image distance will approach as the object distance is increased. You may want to think about this now and test your hypothesis.

### 3.2 The Magnifier

The human eye can focus on objects located anywhere from infinity to a special point called the “near point”. The location of this point varies amongst individuals, but its average value for the adult population is 25cm in front of the eye. If an object is placed closer to the eye than this point, the rays are too divergent for the eye to focus. However, by placing a converging lens between the object and the eye, the rays entering the eye become less divergent. In fact, if the object is placed at the focal point of the lens, the rays entering the eye appear to “come from infinity”. The eye has no problem focusing such rays on the retina.

We now derive an expression for the angular magnification, or magnifying power of a lens, defined as the ratio,

$$m = \frac{\theta_{mag-max}}{\theta_{eye-max}} \quad \text{Equation 12.2}$$

where  $\theta_{eye-max}$  is proportional to the maximum apparent size of the object as seen by the naked eye (*Fig 12.2a*) and  $\theta_{mag-max}$  is proportional to the largest image produced by the lens system (*Fig 12.2b*). These two angles can be approximated by the apparent size of the object at a particular range from the eye (or lens),

$$\theta_{eye-max} \cong \frac{h}{near\ point} \cong \frac{h}{25cm} : \theta_{mag-max} \cong \frac{h}{f} \quad \text{Equation 12.3}$$

These relationships are seen in *Figure 12.2* and only hold for small angles,  $\theta$ . As a result, a good approximation for the magnifying power of a simple lens system is,

$$m = \frac{\theta_{mag-max}}{\theta_{eye-max}} \approx \frac{h/f}{h/25cm} = \frac{25cm}{f} \quad \text{Equation 12.4}$$

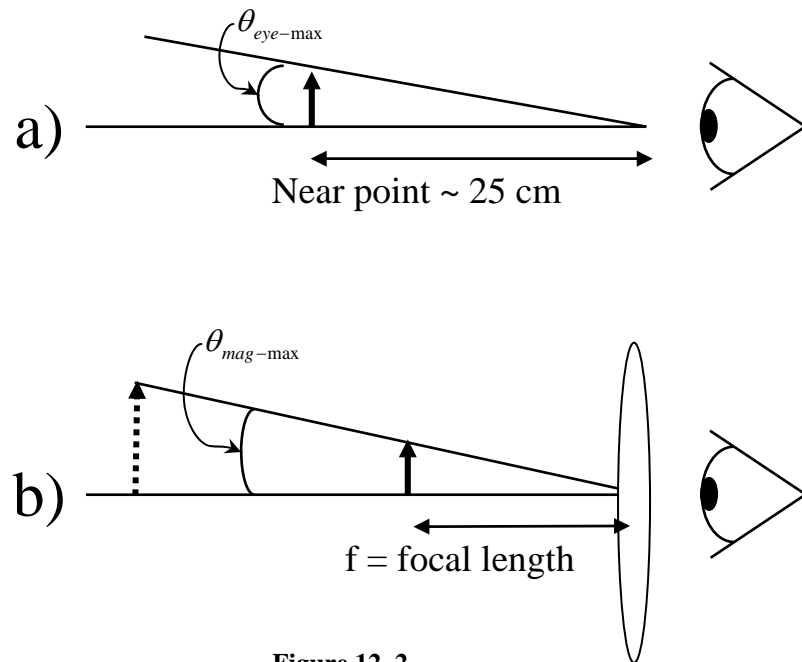

**Figure 12. 2**

### Procedure

1. Estimate the location of your eye's near point. Hold the crossed arrow target at arm's length and slowly bring it towards your eye, with one eye closed. Keep your eye relaxed and do not try too hard to keep the target in focus. As the target moves closer to your eye, there will be a point at which you can no longer focus easily on the target. This is your eye's near point. Measure this distance from eye to target, taking care not to poke your eye out. Place a convex lens between your eye and the target (still at the near point). Verify that you can now focus on the target. The convex lens has allowed you to bring the object closer to your eye, thus making it appear larger. This is how a simple Magnifier works. For the rest of this experiment, whenever an equation includes the average near point, 25cm, you may use the measured value for your eye instead.
2. Set up the Magnifier as shown in *Figure 12.3*. Use the crossed arrow target as your object. Place the 75mm convex lens about 2cm away from the object and view it through the lens. Increase the object distance, the distance between lens and object, until the size of the image is maximized yet still in focus. This should occur when the object distance is approximately equal to the focal length of the lens. Note that beyond this point, the image becomes blurry.
3. Measure the magnification of the lens using the following procedure. While looking through the lens at the object, hold a ruler between your eye and the lens and measure the apparent height of the object (the height of an arrow, for instance.) Repeat the measurement again holding your eye, the ruler and the object in the same place, but with the lens removed from its holder. It may be helpful to have one person make the visual measurement while another person removes (and replaces) the lens. You may need to

repeat this a few times to get the hang of it. Record your data, focal length, and image observations in *Section 4.2*.

- Repeat *Steps 2-3* with a 150mm focal length convex lens (#15).

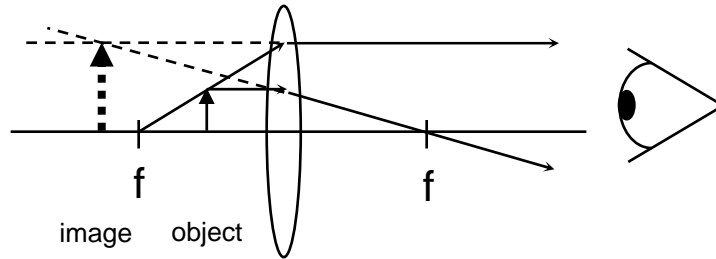

**Figure 12.3**

### 3.3 The Compound Microscope

The Compound Microscope (*Figure 12.4*) uses two lenses to create a magnified image of a very small, very close object. The lens closest to the object is called the objective lens; the one closest to the observer is called the eyepiece. The objective functions as a Projector, producing a real, magnified, inverted image. The eyepiece functions as a Magnifier (having as its object the

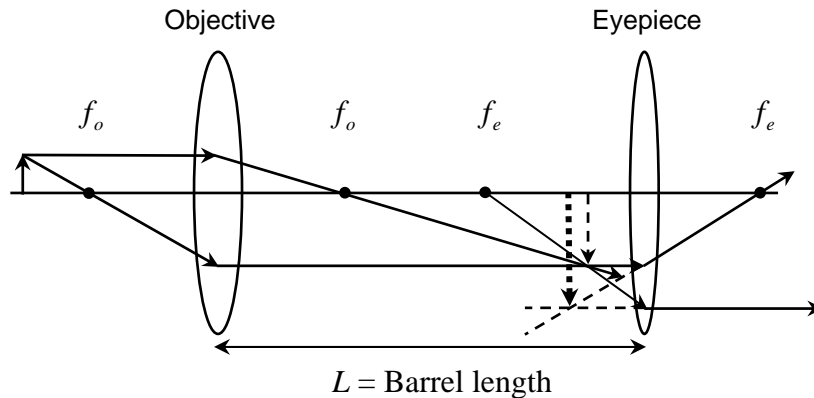

**Figure 12.4**

image from the objective lens), enlarging the image produced by the Projector. The objective lens has a smaller focal length. The object is placed slightly beyond the focal point of the objective in a location as to form an enlarged, real image inside the focal point of the eyepiece. The eyepiece is adjusted to form an enlarged virtual image about 25 cm from the viewer, at the eye's near point. By having the image at the near point, its apparent size is maximized and the eye is kept relaxed.

The total magnification of the microscope,  $M$ , is the product of the lateral magnification of the objective lens,  $m_o$ , and the angular magnification of the eyepiece,  $m_e$ ,

$$M = m_o m_e \quad \text{Equation 12.5}$$

The lateral magnification of a lens is defined as the ratio of the image height to the object height. The magnification of the objective lens alone can be identified from the ratio of its image dimensions to its object dimensions,

$$m_o = \frac{\text{image height}}{\text{object height}} = -\frac{i}{o} \quad \text{Equation 12.6}$$

where the negative sign denotes that the image is inverted, and  $i$  and  $o$  are still the image and object locations, respectively. For the case of a Compound Microscope's objective lens, we know the object distance will be slightly greater than the focal length, so the image distance will be positive and the image itself will be inverted. The barrel length,  $L$ , is a measurable quantity defined as the separation between the two lenses. The image distance will be approximately equal to the difference between the barrel length and the eyepiece's focal length. The magnification of the eyepiece is simply that of a Magnifier, as was studied in *Section 3.2*. Finally, using the Thin-lens Equation to solve for the first image distance, the Compound Microscope's total magnification can be stated,

$$M = -\left(\frac{i}{o}\right)\left(\frac{25}{f_e}\right) \cong -\left(\frac{L - f_e}{o}\right)\left(\frac{25\text{cm}}{f_e}\right) \quad \text{Equation 12.7}$$

## Procedure

1. Construct a Compound Microscope on the optical bench as in *Figure 12.4*. You may need to use 2 tracks to form one long bench. Use the 75mm convex lens as the objective and the 150mm convex lens as the eyepiece. Place the crossed arrow target 12.5cm in front of the objective lens. Start with the 2 lenses about 50cm apart. As you look through the microscope, move the eyepiece closer to the objective until you see a clearly focused image of the arrow target (perhaps only the center portion of the crossed arrow target.)
2. Measure the magnification of the system. Use the same method as was described in *Step 3* of the procedure for the Magnifier (*Section 3.2*). This time, you will measure the apparent size of the arrows with both lenses in place, then with both lenses removed. Record your measured apparent heights in *Section 4.3*.
3. While looking through the microscope, move the objective lens closer to the target and adjust the eyepiece as needed to keep the object in focus as well as you can.
4. Record your data, the focal lengths, and your observations of the image in *Section 4.3*.

### 3.4 The Astronomical Telescope

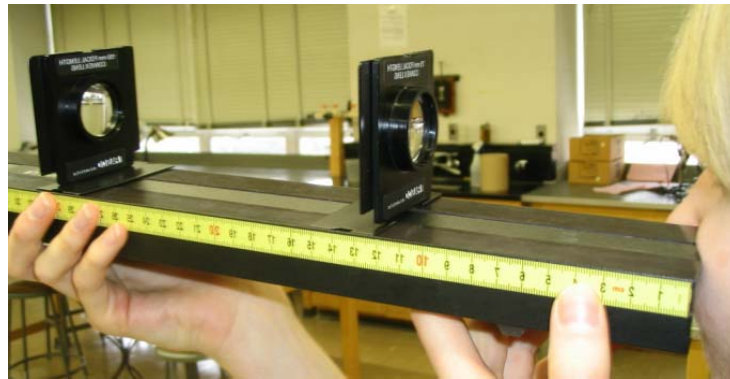
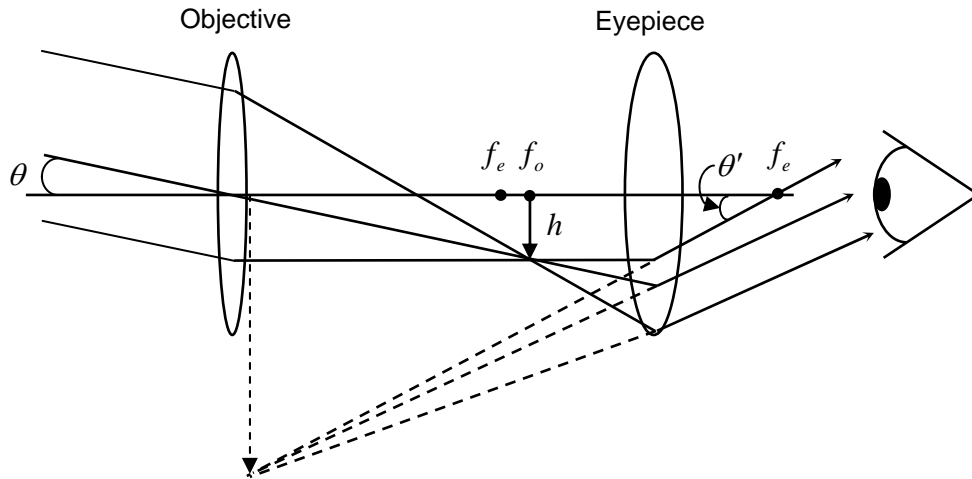

Figure 12. 5

An Astronomical Telescope is used to obtain magnified images of distant objects. Like the Compound Microscope, it is an instrument composed of two lenses, an objective and an eyepiece. Rays from a distant object will be focused by the objective to a point very near to its focal length. A real, inverted image is formed. The Astronomical Telescope is designed so the image from the objective lens forms at the focal point of the eyepiece. Again, the eyepiece acts as a simple Magnifier. But in this case, the final image (the image from the eyepiece) is enlarged, inverted and located “at infinity.” The distance between the two lenses will be very close to the sum of their foci. The total magnification of the system will be derived from the angular magnification (here the lateral magnification is not used as the size of distant, usually galactic, objects are so much greater than the image sizes that the lateral magnification is meaningless). Consider the diagram in *Figure 12.5*. The rays from the distant object subtend a small angle,  $\theta$ , with the lens axis and will form an image of height,  $h$ , near the focal point,  $f_o$ . Two triangles are formed as shown in the diagram. The first

triangle has an angle,  $\theta$ , with a tangent of  $h/f_o$ , the second triangle has an angle,  $\theta'$ , with a tangent of  $h/f_e$ . Using the small angle approximation,

$$\theta \approx \tan \theta = \frac{h}{f_o} \quad : \quad \theta' \approx \tan \theta' = \frac{h}{f_e} \quad \text{Equation 12.8}$$

and the definition of magnification from Equation 12.2, the total magnification of an Astronomical Telescope becomes (the minus sign takes into account the image inversion),

$$M = \frac{\theta'}{\theta} \approx \frac{\tan \theta'}{\tan \theta} = \frac{h/f_e}{h/f_o} = -\frac{f_o}{f_e} \quad \text{Equation 12.9}$$

where we have inserted a minus sign to indicate that the image is inverted.

### Procedure

1. Construct an astronomical telescope on the optical bench as in *Figure 12.5*. Use the 75mm convex lens as your eyepiece, and the 150mm lens as the objective lens. The distance between the two lenses will be approximately 225mm (the sum of the lens' focal lengths.) Look at some reasonable distant object, perhaps a poster on the farthest wall. Adjust the distance between the lenses to bring the object into sharp focus.
2. Measure the magnification of the telescope. Use the same procedure for estimating magnification as was used in the previous two sections. Remember, measure the apparent height of the distant object with the two lenses in place and then with both lenses removed.
3. Record your measurements, the lens' focal lengths, and observations of the image (inverted / erect, etc.) in *Section 4.4*.

## 3.5 The Terrestrial Telescope (or Opera Glass)

As in the case of the Astronomical Telescope, the Terrestrial Telescope is a two-lens system used for imaging distant objects. It uses a long focal length objective lens and a short focal length eyepiece. But in the Terrestrial Telescope, a concave lens or “meniscus” lens replaces the convex eyepiece. The total magnification will be found in the same fashion as the Astronomical Telescope, Equation 12.9.

### Procedure

1. Construct a Terrestrial Telescope on the optical bench. Use the same lens for the objective as you did in the Astronomical Telescope (150mm convex) but replace the convex eyepiece with a 49mm concave eyepiece (#19). The focal length of this concave lens is,  $f_e = -49\text{mm}$ .
2. Put the eyepiece at one end of the optical bench. Place the objective about 20cm from the concave eyepiece and aim the telescope at a distant object, perhaps the same one used in *Section 3.4*. Slowly move the objective toward the eyepiece until the distant object comes into focus.
3. Measure the apparent magnification of the telescope using the same procedure as before. Measure the apparent height of the distant object with and without both lenses.

4. Record your measurements, the lens' focal lengths, and observations of the image (inverted / erect, etc.) in *Section 4.5*.

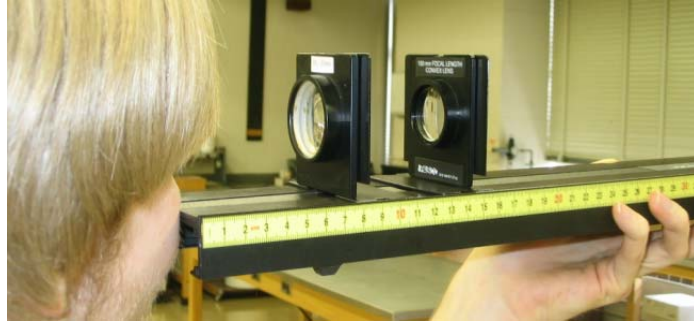

Name: Partners' Names:

Laboratory Section:

Laboratory Section Date:

Grade:

Last Revised on August 31, 2005

# EXPERIMENT 12

## Geometrical Optics

### 4. Post-Laboratory Work [18 pts]

#### 4.1 The Projector [7pts]

Table 12.1 (1pt)

Object Distance ( $o$ )	Image Distance ( $i$ )	Uncertainty in $i$ ( $\Delta i$ )	Magnified / Reduced? Real / Virtual? Inverted / Erect?	$\frac{1}{o}$ ( $cm^{-1}$ )	$\frac{1}{i}$ ( $cm^{-1}$ )	$\Delta\left(\frac{1}{i}\right)$

The uncertainty in the inverse image distance,  $\Delta\left(\frac{1}{i}\right)$ , may be calculated from error propagation,

$$\Delta\left(\frac{1}{i}\right) = \frac{\Delta i}{i^2} \quad \text{Equation 12.10}$$

1. As the object distance,  $o$ , gets larger, the image distance,  $i$ , approaches some value. Estimate this value from your measurements. (1pt)

2. On the axes below, plot  $\frac{1}{i}$  versus  $\frac{1}{o}$  (y vs x). Include your calculated error bars for the y-axis data. Include labels and units for the axes. Draw a best-fit straight line through your data points. Determine the slope and y-intercept of this line. Show your work below. (3pts)

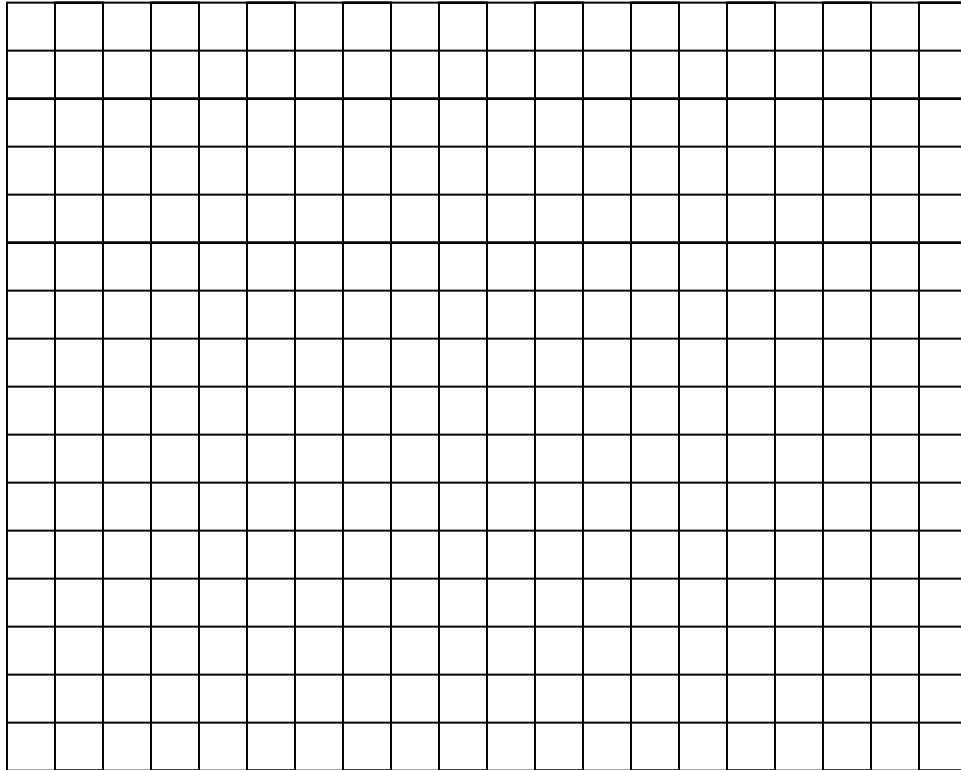

3. What is the focal length of the lens used in The Projector according to your plot? Use the Thin-Lens formula (Equation 12.1), the equation for a line ( $y = mx + b$ ), and what you plotted on the graph. (1pt)
4. Is the Thin-Lens formula verified according to your data and graph? Explain your answer. (1pt)

#### 4.2 The Magnifier [3pts]

75mm Lens

height with lens: \_\_\_\_\_

height without lens: \_\_\_\_\_

$M_{75\text{mm}}$  (measured): \_\_\_\_\_

150mm Lens

height with lens: \_\_\_\_\_

height without lens: \_\_\_\_\_

$M_{150\text{mm}}$  (measured): \_\_\_\_\_

5. Calculate the theoretical magnifications of each lens using your eye relief value. Show your work. (1pt)
  
  
  
  
  
  
  
  
  
  
6. How does your measured magnification compare to the theoretical magnification? Explain why it agrees or disagrees and give specific reason(s) having to do with your actual procedure. (2pts)

#### 4.3 The Compound Microscope [3pts]

$f$  of Objective lens: \_\_\_\_\_

height with lenses: \_\_\_\_\_

$M$  (measured): \_\_\_\_\_

$f$  of Eyepiece: \_\_\_\_\_

height w/o lenses: \_\_\_\_\_

Barrel length,  $L$ : \_\_\_\_\_

7. Calculate the theoretical magnification of your Compound Microscope (Equation 12.7). Show your work. (1pt)

8. Is your calculated magnification consistent with the measured value? Why or why not? (1pt)

9. Why does the magnification increase as the objective lens is moved closer to the object? What focusing problems tend to develop as the magnification increases? (1pt)

#### 4.4 The Astronomical Telescope [2pts]

$f$  of Objective lens: \_\_\_\_\_  $f$  of Eyepiece: \_\_\_\_\_

height with lenses: \_\_\_\_\_ height w/o lenses: \_\_\_\_\_

M (measured): \_\_\_\_\_

Image description:

10. Calculate the theoretical magnification of your Astronomical Telescope (Equation 12.9). Show your work. (1pt)

11. Compare your calculated magnification to the measured one. Are they consistent? Why or why not? (1pt)

#### 4.5 The Terrestrial Telescope [3pts]

$f$  of Objective lens: \_\_\_\_\_  $f$  of Eyepiece: \_\_\_\_\_

height with lenses: \_\_\_\_\_ height w/o lenses: \_\_\_\_\_

M (measured): \_\_\_\_\_

Image description:

12. Calculate the theoretical magnification of your Terrestrial Telescope (Equation 12.9). Show your work. (1pt)

13. What is the main difference between the two telescopes' performance (other than the eyepiece)? When would you use the Astronomical Telescope? The Terrestrial Telescope? (2pts)