

Name _____ Date: _____ Course number: _____
MAKE SURE TA & TI STAMPS EVERY PAGE BEFORE YOU START

Laboratory Section: _____ Partners' Names: _____

Last Revised on September 21, 2016

Grade: _____

EXPERIMENT 13

The Wave Nature of the Electromagnetic Spectrum

0. Pre-Laboratory Work [2 pts]

- 1.) Derive an expression for $\left(\frac{\Delta\lambda}{\lambda}\right)^2$ from the equation $\lambda = d \sin \theta$ using the method of error propagation as found in Appendix B: Error Analysis (available on the web at www.pas.rochester.edu/~physlabs). (1 pt)

- 2.) How can you determine the slit separation by observing the interference pattern as seen in *Section 3.1*? Explain your reasoning. (1 pt)

EXPERIMENT 13

The Wave Nature of the Electromagnetic Spectrum

1. Purpose

The purpose of this experiment is to observe interference patterns, and to calculate the wavelengths of a helium-neon laser and a microwave source using the observed interference patterns.

2. Introduction

The prevailing view of the nature of light has changed several times in the past three centuries. Newton described light as a stream of particles, partly because of its property of straight line travel. In the 19th century, the notion that light consists of waves came into acceptance. In this century it has been shown that light, or more generally any part of the electromagnetic spectrum, behaves with both particle-like and wave-like properties. One method of observing the wave-like nature of light is through the interference and diffraction of electromagnetic radiation.

3. Laboratory Work

3.1 Double Slit Interference

For this part of the experiment you will be using a helium-neon laser, the double slit portion of multiple slit slide, a screen, and a ruler to determine the wavelength of the laser light. We know that the spacing, y , between the fringes of a double slit interference pattern depends on the screen to slit slide (screen-slit) distance, L , the slit separation, d , and the wavelength, λ , in the following form (assuming that $\sin \theta \approx \theta$):

$$y = \frac{\lambda L}{d}$$

Equation 13.1

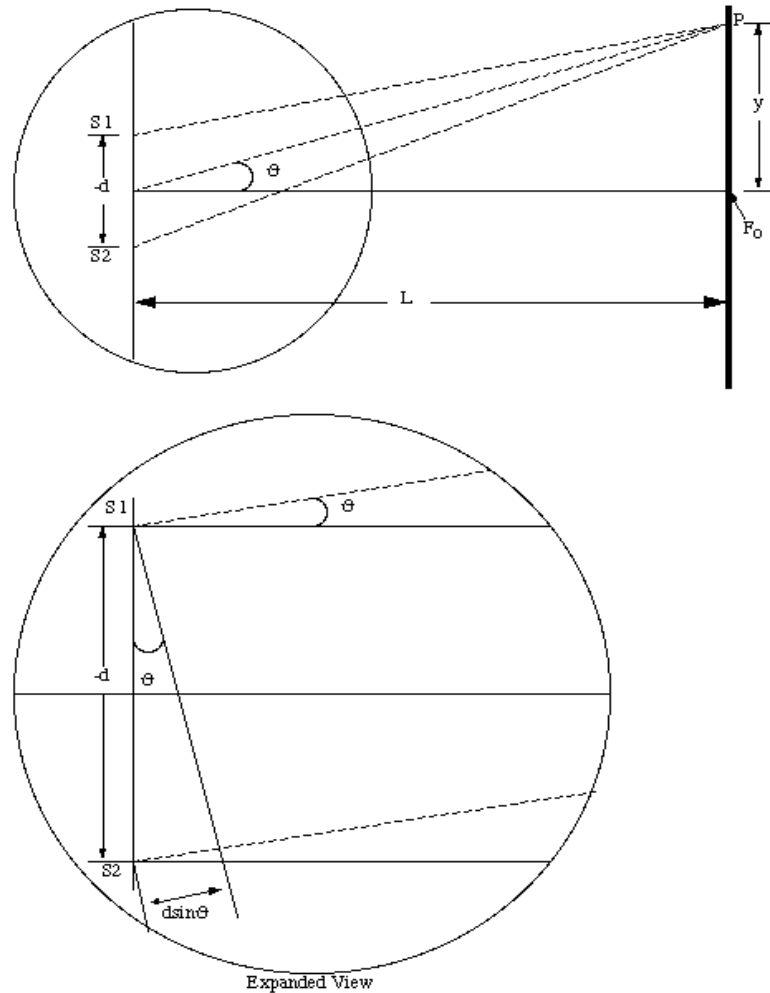
MAKE SURE TA & TI STAMPS EVERY PAGE BEFORE YOU START**Figure 13.1****Procedure**

- 1.) Using the microscope, carefully determine the separation of the two slits, d , on the slide. Determine the uncertainty in the measured separation. If necessary, convert your result to centimeters.

Turn the screw in only one direction to avoid `backlash' errors. Your lab assistant will help you. (This measurement does not need to be made first. Since there is only one microscope, you may want to wait a while to avoid the queue.)

- 2.) Set up the apparatus as shown in the diagram below. Install the slide in the holder and place it in front of the laser. Aim the laser at the double slit portion of your slide and send the back-reflection from the grating back into the laser cavity. This helps to ensure that the d you measured for the slit separation is the d used in the experiment.

CAUTION: Do not look directly into a laser beam or allow it to fall on your eyes.

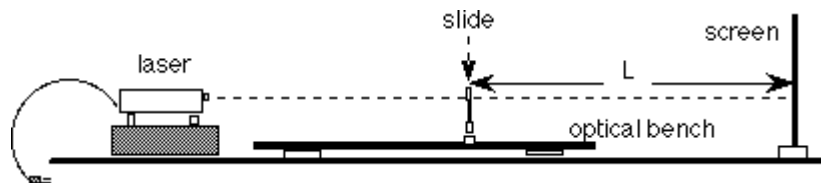

Figure 13.2

- 3.) Place the screen at the other end of the table from the laser, maximizing L . When the laser is turned on, a series of (dim) parallel vertical fringes will be seen on the screen. The spacing of the fringes, y , depends on the screen-slit length, L , and the wavelength, λ , as seen from Equation 13.1.
- 4.) Sketch the fringes on Graph 13.1. The brightest fringe (or maximum) on the screen, seen at F_0 in Figure 13.1, is called the zero-order fringe. This is because the path-length from each of the two slits to F_0 is the same; the path-length difference at F_0 is zero. The two adjacent bright fringes on each side are the first-order fringes (or first-order maximum) with a path-length difference of one wavelength. The next pair are the second-order fringes (or second-order maximum) with a path-length difference of two wavelengths, and so on. Use shaded bars or lines to indicate the bright fringes.
- 5.) Measure the separation, y , for two corresponding fringes. Be sure that you measure the center-to-center distance rather than the edge-to-edge distance. However, a better way of measuring the separation is to measure the separation of six or eight fringes and then divide by the number of fringe spacings measured. This will allow you to find the average separation of two adjacent fringes. Furthermore, because the fringes are not sharp lines, you may want to make several measurements.
- 6.) Finally, measure the distance, L , from the slits to the screen. Then use L , d , and y to calculate the wavelength of the laser light. Compare your experimental value of $\lambda_{\text{He:Ne}}$ to the actual value of 632.8 nm. Calculate $\Delta\lambda$, using the uncertainty in L , d , and y .

3.2 Single Slit Diffraction

In this section of the lab we will be using the single slit portion of the slide to observe how the pattern changes as we decrease the number of slits in our grating.

Procedure

- 1.) Aim the laser at the single slit portion of the slide. When the laser is aimed properly, a pattern is visible on the screen.
- 2.) Sketch to scale the appearance of the pattern you see on the screen on Graph 13.1. Use shaded bars or lines to indicate the bright fringes. In your sketch, identify the zero-order fringe. Draw the scale of the pattern on your sketch so that you can compare it to the fringe pattern produced by the double slit.

3.3 Multiple Slit Interference

In this section of the lab we will be using the multiple slit portion of the slide to observe how the interference pattern changes as we increase the number of slits in our grating.

Procedure

- 1.) Aim the laser at the four slit portion of the slide. When the laser is aimed properly, an interference pattern is visible on the screen.
- 2.) Sketch to scale the appearance of the interference pattern you see on the screen on Graph 13.2. Use shaded bars or lines to indicate the bright fringes. In your sketch, identify the zero-order fringe. Draw the scale of the interference pattern on your sketch so that you can compare it to the fringe pattern produced by other slit combinations.
- 3.) Repeat for the six slit grating, again sketching the appearance of each of the fringe pattern to scale on Graph 13.2.

3.4 Wire Screen Interference

In this section of the lab we will be looking at an interference pattern caused by a wire screen.

Procedure

- 1.) Place the wire screen, which is just a section from a screen window, in the holder and aim the laser beam so that it passes through the wire screen.
- 2.) Sketch the appearance of the interference pattern on Graph 13.3. Explain your observation.
- 3.) When done with the wire, put it back in the appropriate location.

3.5 Microwave Double Slit Interference

In this part, we explore the wave-like nature of a different part of the electromagnetic spectrum. We will use a microwave transmitter and receiver apparatus (see Figure 13.3) to determine the wavelength of microwave radiation. As in the optical counterpart, interference maxima and minima will be produced by the double slit. Here, however, the separation of the maxima will be measured as an angle, not a displacement. The receiver has a meter used to measure the intensity of the radiation received.

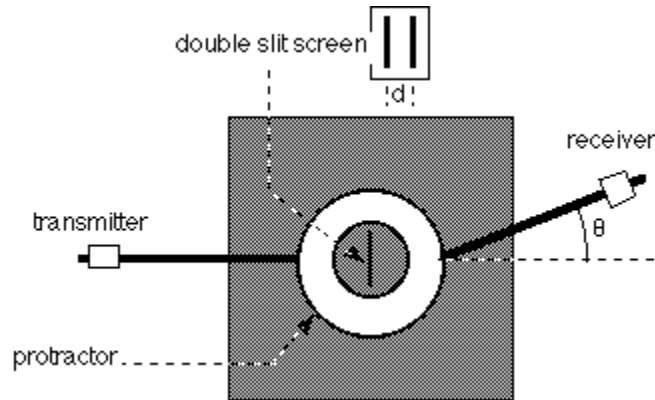

Figure 13.3

Procedure

- 1.) Use calipers to determine the separation of the **centers** of the double slit. Record this value, d .
- 2.) Install the double slit on the turntable at the center between the transmitter and receiver horns.
- 3.) Align the double slit so that it is normal (perpendicular) to the transmitter horn and centered on the transmitter/receiver axis.
- 4.) Reset the protractor scale so that its 180° mark is at the indicator for the transmitter horn.
- 5.) Start with the receiver indicator set at the 0° mark. Record the angle (0°) and the receiver meter reading in Table 13.1.
- 6.) Move the receiver five degrees in one direction, record both the angle and the receiver meter reading in Table 13.1.
- 7.) When you find a maximum or a minimum, record both the angle and the receiver meter reading in Table 13.1 as well.
- 8.) Continue moving the receiver in five degree increments in the same direction until you have passed through two maxima. Record both the angle and receiver meter reading at every position in Table 13.1.
- 9.) Repeat steps 6 and 7 going to the other side of the 0° mark.

Last Revised on September 21, 2016

EXPERIMENT 13

The Wave Nature of the Electromagnetic Spectrum

4. Post-Laboratory Work [20 pts]

4.1 Double Slit Interference and Single Slit Interference[6 pts]

- 1.) Sketch the observed fringes for the double slit interference pattern and the single slit interference pattern in the space provided below. (2 pts)

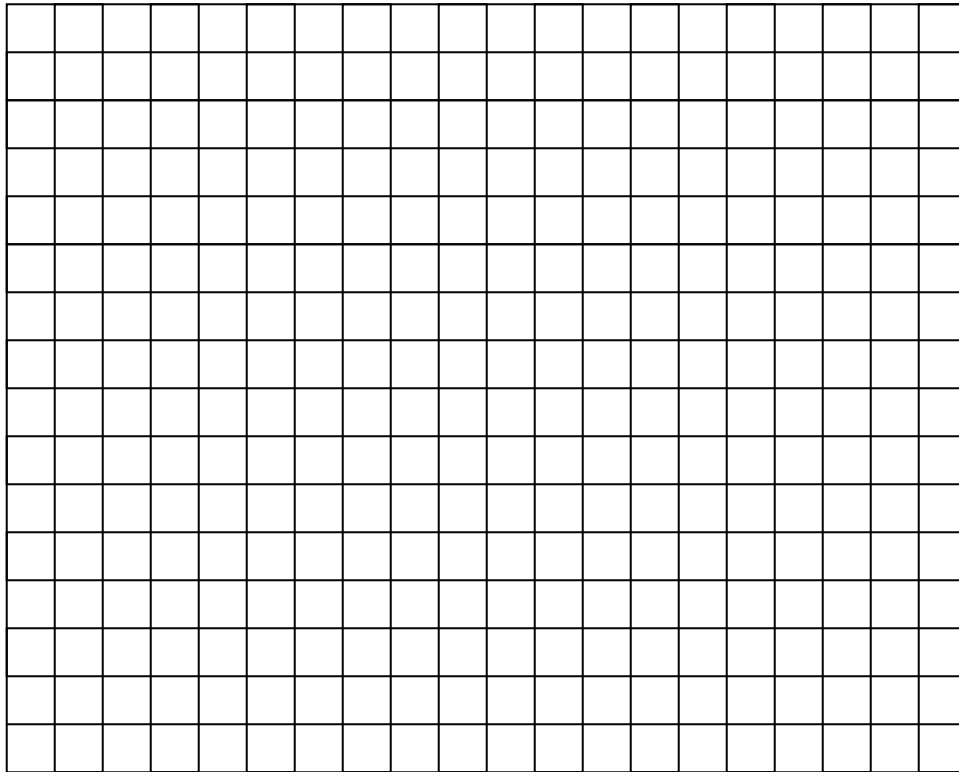

Graph 13.1

- 2.) Record the double slit separation, d , the screen-slit distance, L , and the average separation between adjacent fringes, y . Be sure to use the same units for all your values. (1 pt)

Double slit separation d : _____ Δd : _____

Screen-slit distance L : _____ ΔL : _____

Average fringe separation y : _____ Δy : _____

- 3.) Calculate the wavelength, λ , of the helium-neon laser using the observed double slit interference pattern and Equation 13.1. (1 pt)

- 4.) Determine the error, $\Delta\lambda$, associated with this experimentally determined wavelength, using your uncertainty in L , d , and y . Show your final answer as $\lambda \pm \Delta\lambda$ and compare it to $\lambda_{He:Ne}$ (1 pt).

$$\left(\frac{\Delta\lambda}{\lambda}\right) = \sqrt{\left(\frac{\Delta y}{y}\right)^2 + \left(\frac{\Delta d}{d}\right)^2 + \left(\frac{\Delta L}{L}\right)^2}$$

- 5.) Which parameter of L , d , and y has the greatest influence on $\Delta\lambda$. Explain your answer. (1 pt)

4.2 Single Slit Diffraction [2 pts]

- 6.) Compare the single slit and the double slit fringe patterns. What if anything can you say about the relationship between them? (2 pts)

4.3 Multiple Slit Interference [3 pts]

- 7.) Sketch the interference patterns of the four and six slit gratings in the space provided below.(1pt)

MAKE SURE TA & TI STAMPS EVERY PAGE BEFORE YOU START

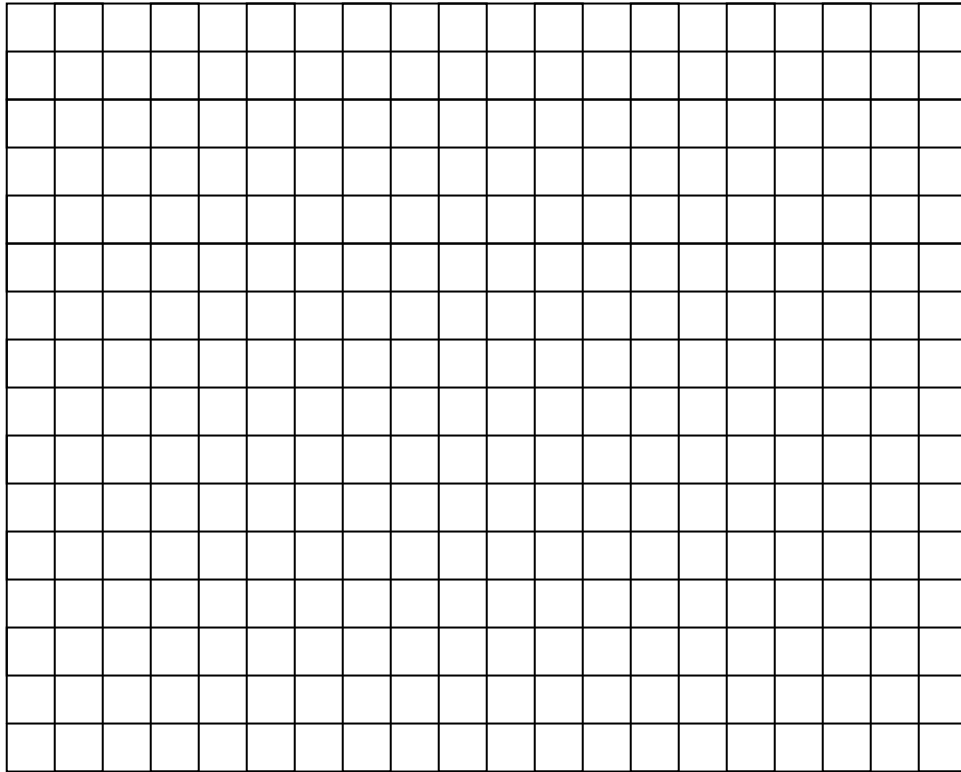

Graph 13.2

8.) What happened to the interference pattern as the number of slits increased? Address issues such as brightness, separation, and sharpness. (1 pt)

9.) Without measuring, do all the sets of slits on the slide have equal separation? How can you tell? (1 pt)

4.4 Wire Screen Interference [3 pts]

MAKE SURE TA & TI STAMPS EVERY PAGE BEFORE YOU START

10.) Sketch the interference pattern for the wire screen below. (1pt)

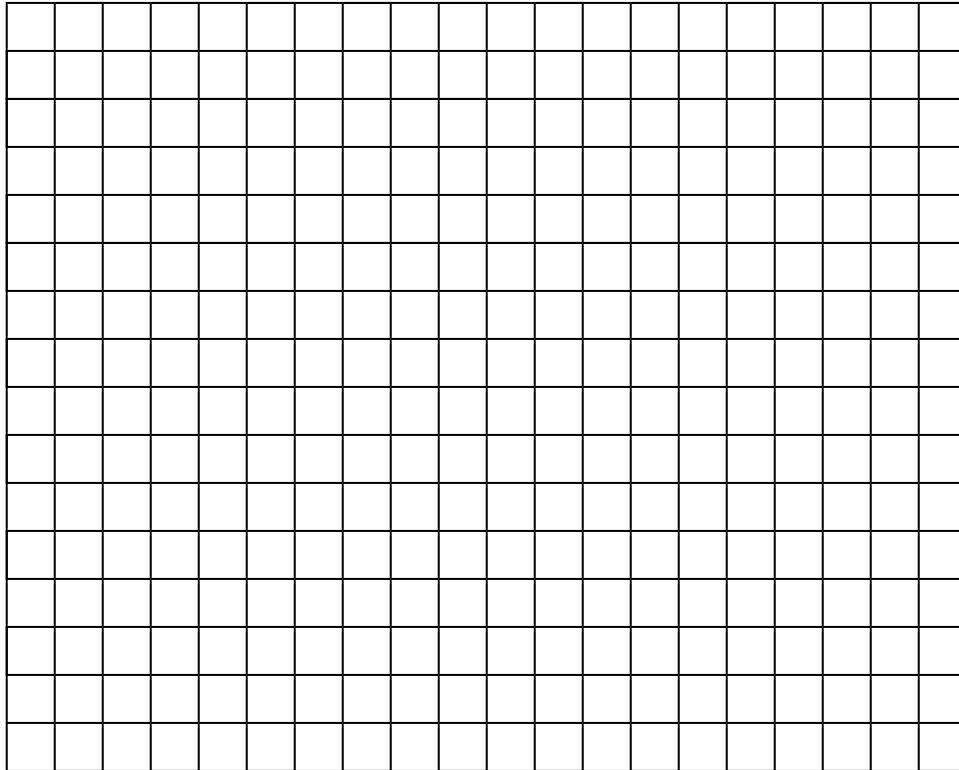

Graph 13.3

11.) How can you create an interference pattern similar to the wire screen interference pattern? Explain your reasoning, if necessary demonstrate or draw a picture showing how to recreate the wire screen interference pattern. (2 pt)

4.5 Microwave Double Slit Interference [6 pts]

12.) Record the angle and receiver meter reading at each of the 5° increments. Record the positions of your maxima and minima as well. (1 pt)

MAKE SURE TA & TI STAMPS EVERY PAGE BEFORE YOU START

occur. Constructive interference can be observed as a maximum on the receiver meter. In this case we find the following:

$$d \sin \theta = m\lambda \quad \text{Equation 13.2}$$

where m is an integer. From Graph 13.4, estimate the angular separation between two adjacent maxima. Record this value below. You may want to find the average angular separation. (1 pt)

Angular separation θ : _____

- 15.) Using the measured value of the double slit separation, d , and the angular separation between adjacent fringes, θ , as found above, calculate the wavelength, λ , of the microwave radiation. (1 pt)

Double slit separation d : _____ Δd : _____

Angular separation θ : _____ $\Delta\theta$ (rads) : _____

Calculated wavelength λ : _____

- 16.) Determine the error, $\Delta\lambda$, associated with this experimentally determined wavelength, using the uncertainty in d and θ . Show your final answer as $\lambda \pm \Delta\lambda$. Typical microwaves are a few centimeters long. (1 pt)

$$\left(\frac{\Delta\lambda}{\lambda}\right) = \sqrt{\left(\frac{\Delta d}{d}\right)^2 + \left(\frac{\Delta\theta}{\tan\theta}\right)^2}$$